

SIEMENS



SAS31.03



SAS61.53



SAS61.33

Acvatix™ Actuators SAS.., SAT.. for valves Basic Documentation

Siemens Switzerland Ltd
Building Technologies Division
International Headquarters
Gubelstrasse 22
6301 Zug
Switzerland
Phone +41 41-724 24 24
www.siemens.com/buildingtechnologies

© Siemens Switzerland Ltd, 2015
Technical specifications and availability subject to change without notice.

Contents

1	About this documentation	5
1.1	Navigation	5
1.2	Revision history	5
1.3	Reference documents	5
1.4	Before you start	5
1.4.1	Trademarks	5
1.4.2	Copyright	6
1.4.3	Quality assurance	6
1.4.4	Document use / request to the reader	6
1.5	Scope of this documentation	6
2	Engineering.....	7
2.1	Product description	7
2.2	Use.....	7
2.3	Type summary	8
2.3.1	Stroke actuators.....	8
2.4	Ordering	8
2.5	Equipment combinations.....	9
2.5.1	2-port / 3-port threaded valves with stroke actuator SAS.....	9
2.5.2	2-port / 3-port threaded valves with stroke actuator SAT.....	9
2.6	Accessories	10
2.6.1	Electrical accessories	10
2.6.2	Mechanical accessories	10
2.7	Product replacements	10
2.7.1	Stroke actuators SAS../SAT.. to SQS.....	10
2.7.2	Electrical accessories	11
2.8	Spare parts	11
2.9	Sizing	12
2.9.1	Parallel operation of actuators.....	12
2.9.2	Permissible cable length and wire cross-sectional area	12
2.10	Warranty.....	13
3	Handling.....	14
3.1	Mounting and installation	14
3.1.1	Mounting positions.....	14
3.1.2	Fitting stroke actuators SAS.. to threaded valves	14
3.1.3	Accessories	15
3.1.4	Wiring (installation)	18
3.2	Commissioning and operation.....	20
3.2.1	Function check and Calibration	20
3.2.2	Maintenance.....	22
3.2.3	Disposal	22
4	Functions and control	23
4.1	3-position control	23
4.2	Modulating control	25
4.2.1	Positioning signal and flow characteristic selection.....	26
4.2.2	Position feedback U.....	27
4.2.3	Calibration	27
4.2.4	Signal priorities	28

4.2.5	Detection of valve seat.....	29
4.2.6	Detection of foreign bodies	30
4.2.7	Forced control Z	30
4.3	Technical and mechanical design.....	31
4.3.1	Transmission of power	31
4.3.2	Coupling	31
4.3.3	Fail safe function	32
4.3.4	Manual adjuster	33
4.3.5	Indicators.....	34
4.3.6	Electrical accessories	35
4.3.7	Mechanical accessories.....	35
5	Technical data.....	36
6	Connection diagrams and dimensions.....	38
6.1	Internal diagrams.....	38
6.2	Connection terminals	39
6.2.1	Actuators	39
6.2.2	Electrical accessories	40
6.2.3	Cable labeling.....	40
6.3	Connection diagrams.....	41
6.4	Dimensions.....	42
6.4.1	Stroke actuators.....	42
	Revision numbers	44
7	Glossary.....	45
7.1	Symbols	45
7.2	Terms	45
Index	47	

1 About this documentation

1.1 Navigation

Information about a specific actuator is provided throughout the document. The structure of chapters 2 to 4 is as follows:

2 Engineering 2.1 Product description 2.2 Use	device oriented
3 Handling 3.1 Mounting and installation 3.2 Commissioning and operation	handling oriented
4 Functions and Control 4.1 3-position control 4.2 Modulating control	assembly oriented

4040228en

Note

Glossary and Index are arranged at the end of the document.

1.2 Revision history

Revision	Date	Changes	Chapter
First edition	2016-02-26	-	-
2.0	2016-02-26	Corrections in: Technical Data, Equipment Combinations, use of vocabulary, Mounting Position, Connection Diagrams	2; 3; 4; 5

1.3 Reference documents

Type of document	SAS..	SAT..
Data Sheet	N4581	N4584
Mounting Instructions	lasered on cover	
CE Declaration of Conformity	AC 230 V	T4581X1
	AC/DC 24 V	T4581X2
Environmental Declaration	E4581	E4584

1.4 Before you start

1.4.1 Trademarks

The table below lists the third-party trademarks used in this document and their legal owners. The use of trademarks is subject to international and domestic provisions of the law.

Trademarks	Legal owner
Acvatix™	Siemens Switzerland Ltd

All product names listed in the table are registered (®) or not registered (™) trademarks of the owner listed in the table. We forgo the labeling (e.g. using the symbols ® and ™) of trademarks for the purposes of legibility based on the reference in this section.

1.4.2 Copyright

This document may be duplicated and distributed only with the express permission of Siemens, and may be passed on only to authorized persons or companies with the required technical knowledge.

1.4.3 Quality assurance

These documents were prepared with great care.

- The contents of all documents are checked at regular intervals
- All necessary corrections are included in subsequent versions
- Anpassungen bzw. Documents are automatically amended as a consequence of modifications and corrections to the products described

Please make sure that you are aware of the latest document revision date.

If you find lack of clarity while using this document, or if you have any criticisms or suggestions, please contact the product manager in your nearest branch office.

The addresses of the Siemens regional companies are available at

www.siemens.com/acvatix.

1.4.4 Document use / request to the reader

Before using our products, it is important that you read the documents supplied with or ordered at the same time as the products (equipment, applications, tools etc.) carefully and in full.

We assume that persons using our products and documents are authorized and trained appropriately and have the technical knowledge required to use our products as intended.

More information on the products and applications is available:

- On the intranet (Siemens employees only) at <https://workspace.sbt.siemens.com/content/00001123/default.aspx>.
- From the Siemens branch office near you www.siemens.com/acvatix or from your system supplier.
- From the support team at headquarters fieldsupport-zug.ch.sbt@siemens.com if there is no local point of contact.

Siemens assumes no liability to the extent allowed under the law for any losses resulting from a failure to comply with the aforementioned points or for the improper compliance of the same.

1.5 Scope of this documentation

This document shall serve as a source of knowledge. In addition to basic information, it provides general technical information about the actuators used in HVAC plants. It is also targeted at engineering staff, HVAC electrical planners, system integrators and service engineers and provides all information required for planning work, correct installation, commissioning and service.

2 Engineering

2.1 Product description

The line of small actuators is comprised of stroke actuators SAS.. and SAT..

Mechanical design

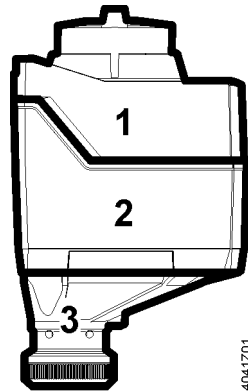

SAS.., SAT..

1	User interface Electrical connections
2	Power transmission and preparation Print Motor
3	Yoke (for assembly of actuator and seat, slipper valve)

Components

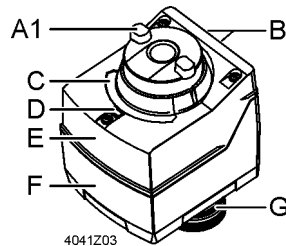

SAS.. / SAT..

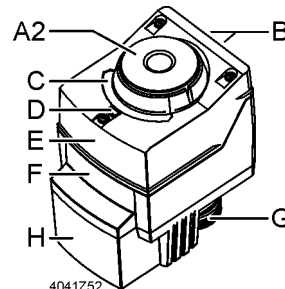

SAS..5.. / SAT..5..

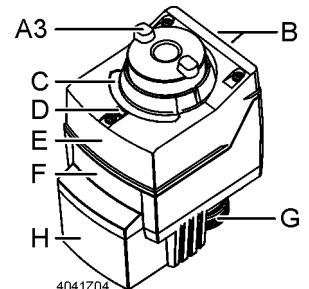

SAS..33..

- A1 Manual adjuster (with slide switch)
- A2 Dummy cover (without manual adjuster)
- A3 Manual adjuster (without slide switch)
- B Cable glands (M16 / M20)
- C Position indication
- D Status indication (SA..61.., 0...10 V)
- E Housing cover
- F Housing
- G Valve stem coupling
- H Housing of spring return

2.2 Use

SAS.. / SAT..

For use in connection with Siemens 2-port or 3-port valves, as control or shutoff valves for HVAC plants.

2.3 Type summary

2.3.1 Stroke actuators

- All types:
- Stroke 5.5 mm
 - Positioning force SAS.. 400 N
SAT.. 300 N

Product no.	Stock no.	Operating voltage	Positioning signal	Power consumption	Positioning time	Fail safe function / Spring return time	Manual adjuster	Position feedback	Remark		
SAS31.00	S55158-A106	AC 230 V	3-position	2.8 / 2.4 VA ⁵⁾	120 s	no / –	yes	-	1)	3)	
SAS31.03	S55158-A107			3.5 / 2.9 VA ⁵⁾	30 s						
SAS31.50	S55158-A108			3.5 / 2.9 VA ⁵⁾	120 s	yes / <28 s ⁶⁾	no				
SAS31.53	S55158-A109			5.5 / 3.8 VA ⁵⁾	30 s	yes / <14 s ⁶⁾					
SAS61.03	S55158-A100	AC/DC 24 V	DC 0...10 V DC 4...20 mA 0...1000 Ω	5.3 / 4.5 VA ⁵⁾	30 s	no / –	yes	DC 0...10 V	1)	2)	
SAS61.03U	S55158-A100-A100			5.3 / 4.5 VA ⁵⁾							
SAS61.33	S55158-A101			5.9 / 4.8 VA ⁵⁾		yes / <14 s ⁶⁾			1)	2)	
SAS61.33U	S55158-A101-A100			5.9 / 4.8 VA ⁵⁾							
SAS61.53	S55158-A102			5.8 / 5.0 VA ⁵⁾		no	1)		4)		
SAS81.00	S55158-A103	AC/DC 24 V	3-position	2.2 / 2.0 VA ⁵⁾	120 s	no / –	yes	-	1)	1)	
SAS81.03	S55158-A104			2.5 / 2.1 VA ⁵⁾							
SAS81.03U	S55158-A104-A100			2.5 / 2.1 VA ⁵⁾					30 s	yes / <14 s ⁶⁾	1)
SAS81.33	S55158-A105			3.4 / 2.4 VA ⁵⁾							
SAS81.33U	S55158-A105-A100			3.4 / 2.4 VA ⁵⁾							
SAT31.008	S55158-A119	AC 230 V	3-position	5.0 / 2.5 VA ⁵⁾	8 s	no / –	yes	-	1)	3)	
SAT31.51	S55158-A120			5.5 / 3.2 VA ⁵⁾	15 s	yes / <8 s ⁶⁾	no				
SAT61.008	S55158-A117	AC/DC 24 V	DC 0...10 V DC 4...20 mA 0...1000 Ω	7.1 / 4.6 VA ⁵⁾	8 s	no / –	yes	DC 0...10 V	1)	4)	
SAT61.51	S55158-A118			6.4 / 4.8 VA ⁵⁾	15 s	yes / <8 s ⁶⁾	no				

- 1) Cable gland: M16 and M20 (ISO50262)
2) Cable gland: ½" (UL514C)
3) Approbation: CE
4) Approbation: CE and UL (only 24 V)
5) Second value: Power consumption in neutral position
6) Spring return time increased slightly at low temperatures

2.4 Ordering

Example

Product no.	Stock no.	Description	Quantity
SAS31.00	S55158-A106	Actuator	1
+ auxiliary components (connections, auxiliary switches...)			

Delivery

Actuators, valves and accessories are supplied in individual packs.

2.5 Equipment combinations

2.5.1 2-port / 3-port threaded valves with stroke actuator SAS..

Typical applications:



- Heating plants
- District heating plants
- Ventilation and air conditioning plants

Actuators

Stroke
Positioning force
Data sheet

SAS..

5.5 mm
400 N
N4581

PN 16	VVG44..	PN 16	VXG44..	SAS..				
Medium	1...120 °C	Medium	1...120 °C	DN	G [Inch]	k _{vs} [m ³ /h]	Δp _{max} [kPa]	Δp _s [kPa]
Data sheet	N4364	Data sheet	N4464					
	VVG44.15-.. ¹⁾		VXG44.15-.. ¹⁾	15	G 1 B	0.25 / 0.4 / 0.63	400	1600
	VVG44.15-.. ¹⁾		VXG44.15-.. ¹⁾	15	G 1 B	1 / 1.6	400	725
	VVG44.15-.. ¹⁾		VXG44.15-.. ¹⁾	15	G 1 B	2.5 / 4	400	400
	VVG44.20-6.3		VXG44.20-6.3	20	G 1 1/4 B	6.3	400	750
	VVG44.25-10		VXG44.25-10	25	G 1 1/2 B	10	400	400
	VVG44.32-16		VXG44.32-16	32	G 2 B	16	250	250
VVG44.40-25	VXG44.40-25	40	G 2 1/4 B	25	125	125		

PN 25	VVG55..	SAS..				
Medium	1...130 °C	DN	G [Inch]	k _{vs} [m ³ /h]	Δp _{max} [kPa]	Δp _s [kPa]
Data sheet	N4379					
	VVG55.15-.. ¹⁾	15	G 3/4 B	0.25 / 0.4 / 0.63	1200	2500
	VVG55.15-.. ¹⁾	15	G 3/4 B	1 / 1.6 / 2.5	1200	2000
	VVG55.20-4	20	G 1 B	4	1000	1000
	VVG55.25-6.3	25	G 1 1/4 B	6.3	800	800

¹⁾ .. = insert k_{vs} value

2.5.2 2-port / 3-port threaded valves with stroke actuator SAT..

Typical applications:

- Heating plants
- Ventilation plants

Actuators

Stroke
Positioning force
Data sheet

SAT..

5.5 mm
300 N
N4584

PN 25	VVG549..	SAT..				
Medium	2...130 °C ¹⁾	DN	G [Inch]	k _{vs} [m ³ /h]	Δp _{max} [kPa]	Δp _s [kPa]
Data sheet	Q4380					
	VVG549.15-0.25	15	G 3/4 B	0.25	1200	2500
	VVG549.15-0.4			0.4		
	VVG549.15-0.63			0.63		
	VVG549.15-1			1		
	VVG549.15-1.6			1.6		
	VVG549.15-2.5			2.5		
	VVG549.20-4K ²⁾	20	G 1 B	4	1600	
	VVG549.25-6.3K ²⁾	25	G 1 1/4 B	6.3		

¹⁾ Briefly 150 °C (up to 150 °C max. 6 of 24 hours), with ALG.B fittings up to 100 °C

²⁾ Pressure compensated

2.6 Accessories

2.6.1 Electrical accessories

Product no.	Accessory	Description
SAS.. / SAT..	ASC10.51	Auxiliary switch

2.6.2 Mechanical accessories

Product no.	Accessory	Description
SAS.. / SAT..	ASK39.2	Weather shield

2.7 Product replacements

Replacement of SQS../SSC.. actuators by SAS.. and SAT.. actuators.

Note

- When replacing actuators consider positioning force.
- Adjust in the controller the parameter "Running time" (corresponds to positioning time + idle stroke) and "Positioning time" if changed, to ensure stable control.
- The replacement of accessory items needs to be taken into consideration also. In that case, compatibility is not necessarily ensured.

2.7.1 Stroke actuators SAS../SAT.. to SQS..

SQS..		Pos. time [s]	Pos. force [N]	SAS../SAT..		Pos. time [s]	Pos. force [N]	VVG44..	VVG55..	VVG549..
Product no.	OEM			Product no.	Pos. time [s]			DN15...40	DN15...25	DN15...25
SQS35.00	SQS359.00/189	150	400	SAS31.00	120	400	✓	✓	-	
	SQS35.000C						✓	✓	-	
	SQS35.00SL						✓	✓	-	
SQS35.03	SQS359.03	35		SAS31.03	30		✓	✓	-	
	SQS359.03/189						✓	✓	-	
SQS35.50	-	150		SAS31.50	120		✓	✓	-	
SQS35.53	-	35	SAS31.53	30	✓	✓	-			
-	SQS359.05	15	250	SAT31.008	8	300	-	-	✓	
-	SQS359.54	20	400	SAT31.51	15		-	-	✓	
SQS65	-	150	400	SAS61.03	30	400	✓	✓	-	
SQS65.2	-	35		-			✓	✓	-	
SQS65.5	-			SAS61.53			✓	✓	-	
SQS65.5U ¹⁾	-			SAS61.33U			✓	✓	-	
SQS65U ¹⁾	-			SAS61.03U			✓	✓	-	
SQS85.00	-		150	SAS81.00	120	400	✓	✓	-	
SQS85.03	-	35	SAS81.03	30	✓		✓	-		
SQS85.53U ¹⁾	-		SAS81.33U		✓		✓	-		

¹⁾ SQS..U: prepared for ½ inch flex conduit connection; SAS..U with ½ inch

2.7.2 Electrical accessories

Notes



- If auxiliary switches are used, their switching points should be indicated on the plant schematic.
- Do not insulate the yoke and housing of the actuator and the valve stem, as air circulation must be ensured.
- **Non-observance of the above may result in accidents and fires!**
- **Do not touch the hot parts without prior protective measures to avoid burns!**

Stroke actuators		SQS..	SAS..
ASC9.6	Auxiliary switch	ASC9.6	ASC10.51

2.8 Spare parts

The following spare parts are available:

SAS..
SAT..

Stock number	Description	
S55845-Z180	Type ASQ1: Housing cover with screws and light conductor as an assembly, without laser marking	

2.9 Sizing

2.9.1 Parallel operation of actuators

SAS31.. and SAS81..

3-position actuators must have one specific controller each; refer to chapter 5.3 Connection diagrams (page 41).

SAS61..

Up to 10 actuators can drive in parallel on a controller output with a rating of 1 mA. Modulating actuators have an input impedance of 100 kΩ.

2.9.2 Permissible cable length and wire cross-sectional area

Cable lengths and wire cross-sectional areas depend on the following criteria of the actuators:

- Current draw
- Permissible voltage drop across the power supply lines

The control accuracy of the modulating actuators can be improved by using 4-wire connections, thus ensuring that voltage drops on G0 will not distort the positioning signal.

Note

When determining the cable length and the wire cross-sectional area, adherence to the permissible operating voltage tolerance at the actuator is of importance, in addition to the permissible voltage drop across the operating voltage and signal lines (see table below).

Product no.	Operating voltage	Terminal	Max. permissible voltage drop
SA..31..	AC 230 V	N, Y1, Y2	2% each (total of 4%)
SA..61..	AC/DC 24 V	G0, Y, U	1% each (at DC 0...10 V)
SA..81..		G, Y1, Y2	4% each (total of 8%)

The following criteria must be considered:

- With modulating control, the permissible positioning signal error must not exceed 1%, the reason being the voltage drop on the G0 wire.
- The voltage drop, caused by charging current peaks in the actuator's DC circuit, must not exceed 2 Vpp.
- If the G0 line is not correctly sized, load changes of the actuator due to changes of the DC voltage drop might lead to self-oscillations.
- The operating voltage drop at AC/DC 24 V may be a maximum of 8% (4% across the G0 wire).

Basic diagram – voltage drop across the power supply cables

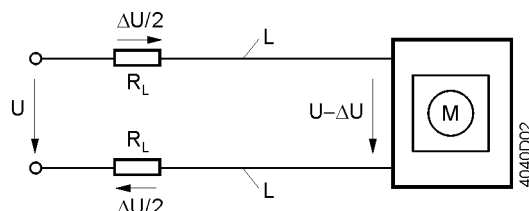

The following diagram can be used to determine the cable lengths and wire cross-sectional areas.

L/P-diagram for AC/DC 24 V

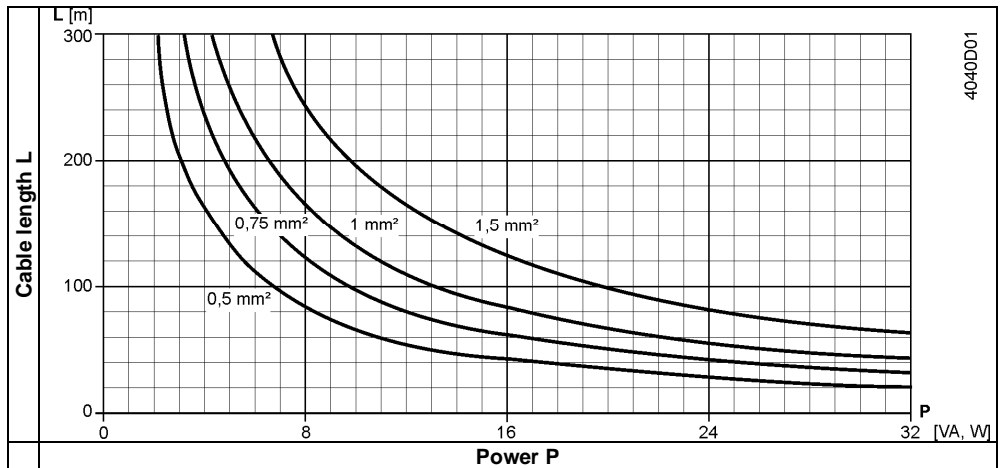

Permissible cable length **L** as a function of power **P** and cross-sectional area of wire as a parameter

Note

P is the decisive power consumption of all actuators connected in parallel. When operating on AC 24 V, power consumption is in VA; when operating on DC 24 V, in W.

Formulas for wire lengths

Operating voltage	Permissible voltage drop / wire	Formula for wire length
AC 230 V	2 % of AC 230 V	$L = 46 \cdot \frac{1313 \cdot A}{P}$ [m]
AC 24 V	4 % of AC 24 V	$L = \frac{1313 \cdot A}{P}$ [m]
	1 % of DC 10 V	$L = \frac{5.47 \cdot A}{I(\text{DC})}$ [m]

- A Cross-sectional area of wire in mm²
- L Permissible wire length in m
- P Power consumption in VA (AC) or W (DC) (see actuator's rating plate)
- I(DC) DC current part (in A) on G0 wire

2.10 Warranty

The engineering data specified in chapter 2.5 Equipment combinations (page 9) are only guaranteed in connection with the Siemens valves listed. Siemens rejects any and all warranties in the event that third-party products are used.

Note

When using the actuators in connection with valves of other manufacture, correct functioning must be ensured by the user, and Siemens will assume no responsibility.

3 Handling

3.1 Mounting and installation

3.1.1 Mounting positions

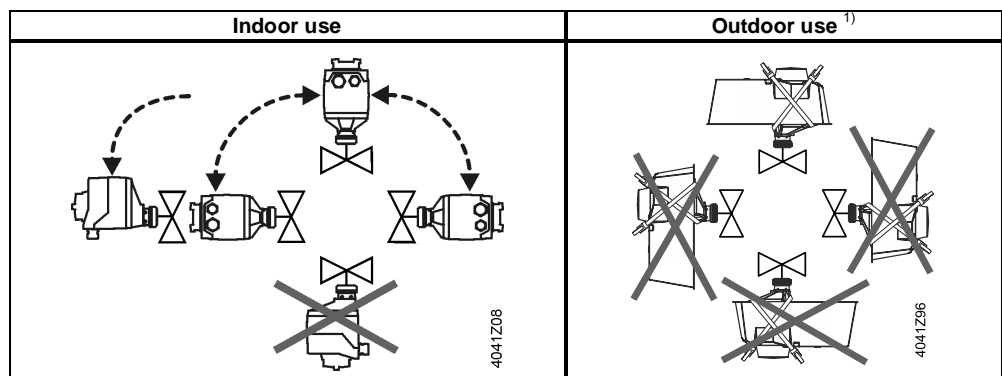

¹⁾ Only in connection with weather shield ASK39.2, housing protection IP54 remains unchanged

3.1.2 Fitting stroke actuators SAS.. to threaded valves

First, observe chapter 3.1.1 Mounting positions.

SAS..0..
SAT..0..

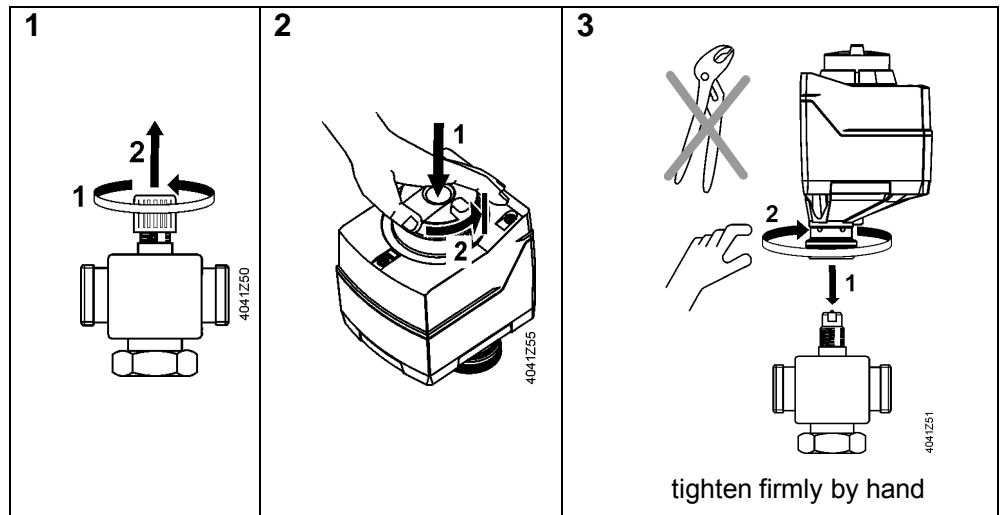

SAS..5..

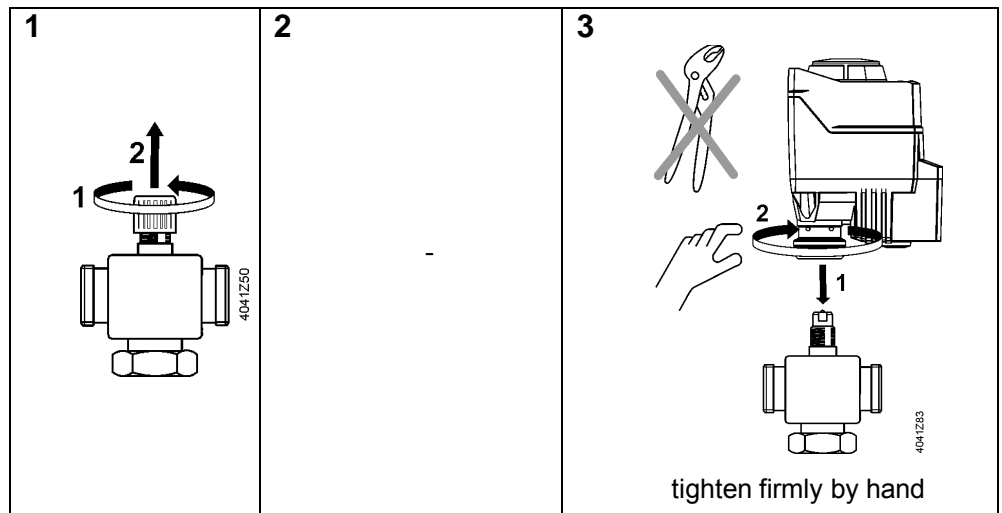

3.1.3 Accessories

Special notes on mounting



Before fitting the accessory items shown below, the following steps must be performed:

1. Actuator is mechanically connected to a Siemens valve.
2. Observe compatibility and choice of combinations. Refer to 2.6 (page 10).
3. Disconnect actuator, auxiliary switch from power.

Attention if AC 230 V connected danger of life!

4. Only required with actuators without fail safe function: Using the manual adjuster, drive the actuator's stem to the fully retracted position and fix the coupling. See "Manual operation" and "Fixing the position" (page 33).
5. To fit an auxiliary switch the housing cover must be removed and the M16 knock-out broken out.

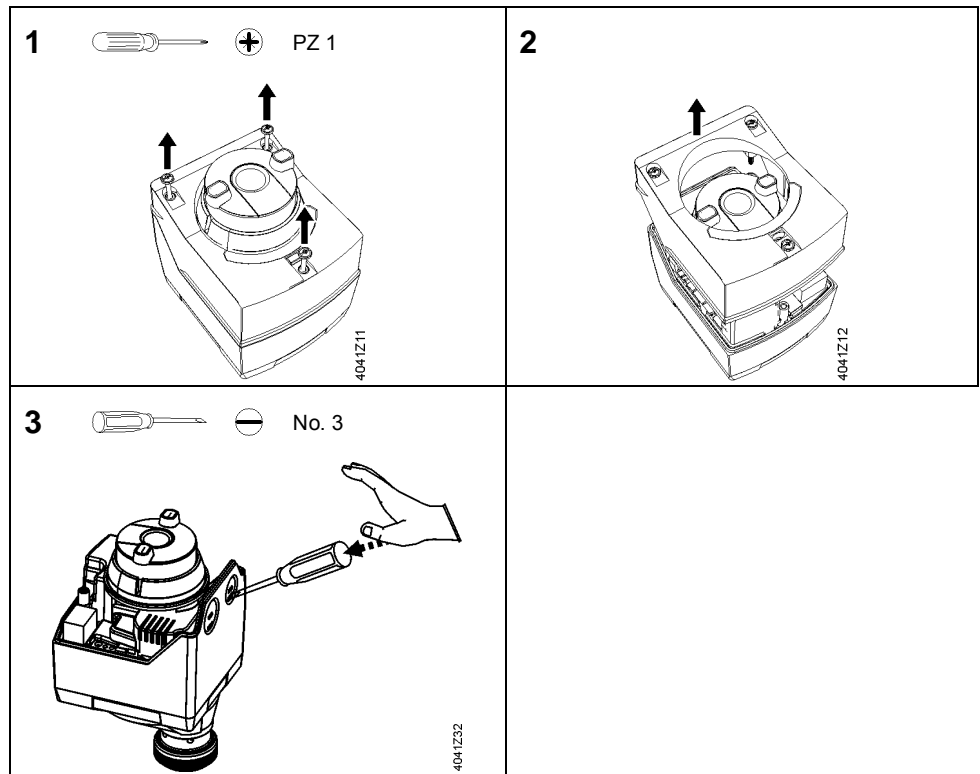

Interior view

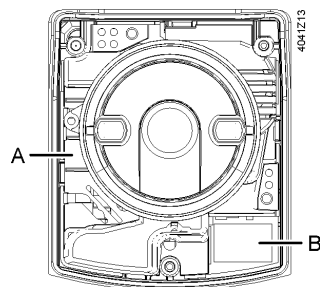

- A Plug-in space for accessory
- B Connection terminal

Auxiliary switch ASC10.51

Scope of delivery

- 1 auxiliary switch
- 1 screw
- cable ties

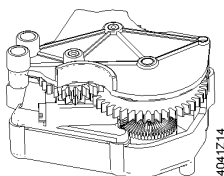

Plug-in space for
accessory

First, observe "Special notes on mounting" (page 15).

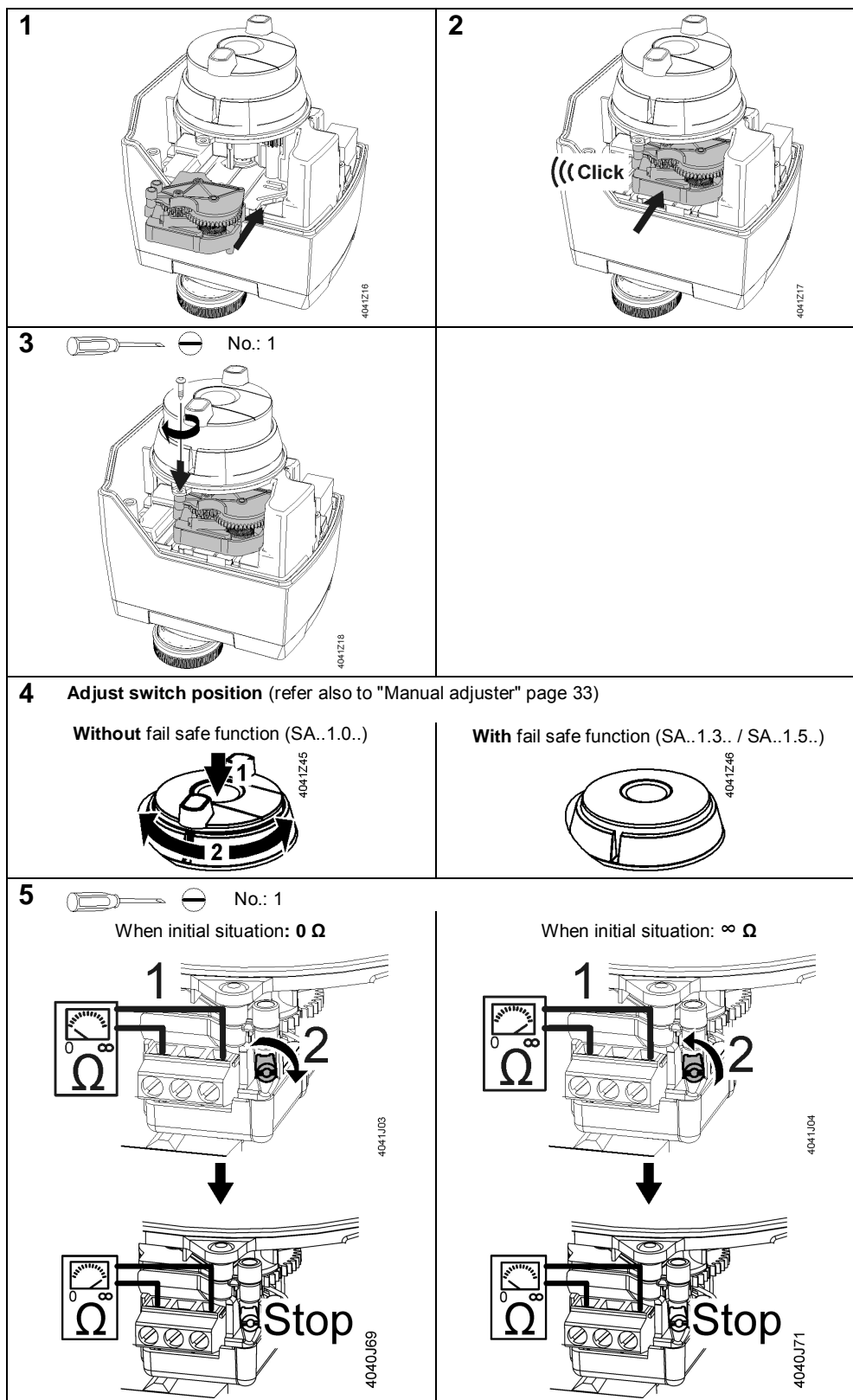

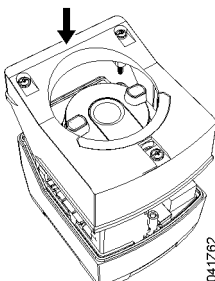
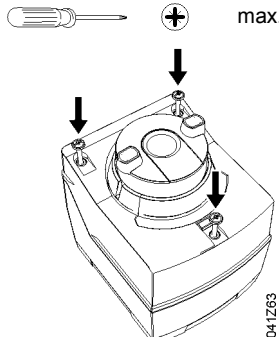
6 Observe "Wiring (installation)" (page 18)	7 Observe "Connection terminals" (page 39)
8  4041Z62	9  4041Z63

Note

Before commissioning with the control, check the exact position again; see "Auxiliary switch", page 21.

Weather shield ASK39.2

First, observe "Special notes on mounting" (page 15).

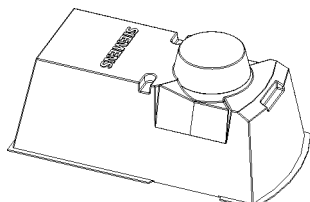
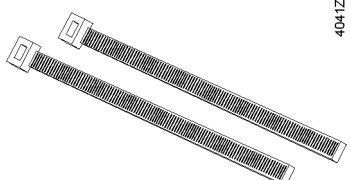
Scope of delivery	
Weather shield ASK39.2  4041Z25	2 UV-proof cable ties  4041Z26

Notes

- To protect the actuator from weather effects when used outdoors, the weather shield must always be fitted. The housing protection IP54 remains unchanged.
- If fitted several times, 2 UV-proof cable ties (700 x 7 mm) must be used when fitted again.
- The manual adjuster cannot be used when the weather shield is mounted.

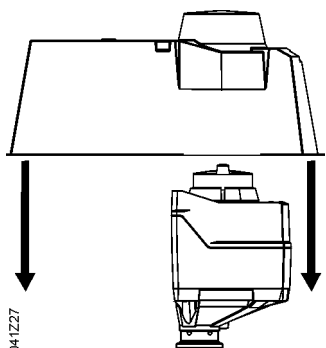
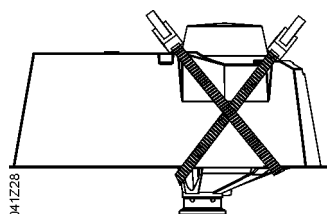
1  4041Z27	2  4041Z28
---	---

3.1.4 Wiring (installation)

Conduct the electrical connections in accordance with local regulations on electrical installations as well as chapter 5.2 "Connection terminals" on page 39.

Preparation of wire endings

The cable endings must be prepared before as follows:

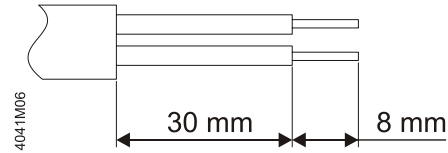

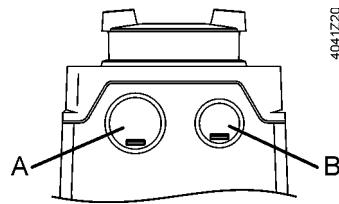

Cable entries

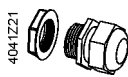
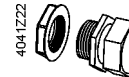

A	EU: M20 US: 1/2"	Connection actuator
B	EU: M16 US: 1/2"	Connection accessories

Cable glands

Cable glands (not contained in scope of delivery)		
Metric	Metric	Inch thread
M16	M20	1/2"
 4041Z21	 4041Z22	 4041Z23

Notes

- Without cable gland IP protection is **not** guaranteed!
- Guide the cable in a loop to the cable gland, so water can drop off.

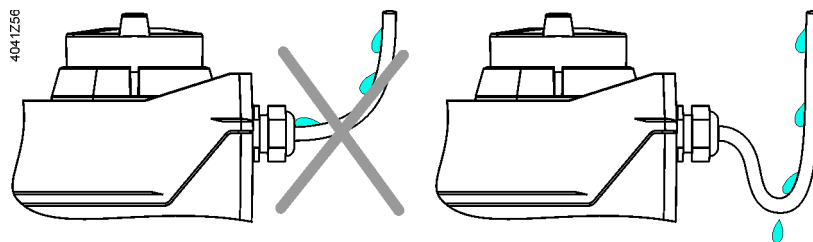



Preconditions

Prior to installation, the following preconditions must be satisfied:

- Actuator is mechanically connected to a Siemens valve.
- Housing cover is removed.

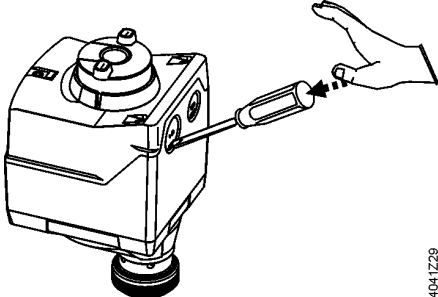
Actuator

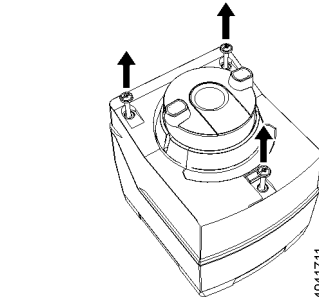
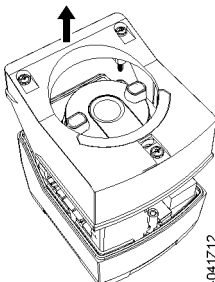
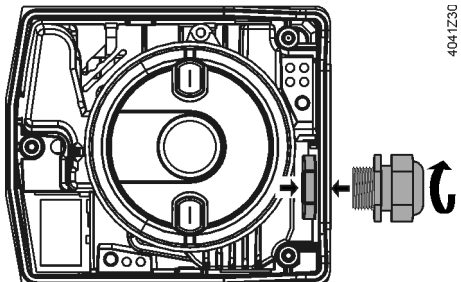
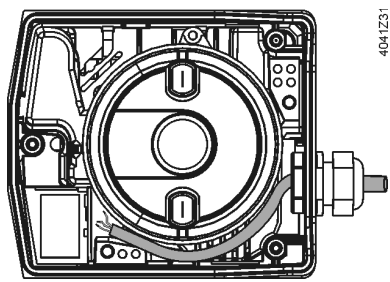
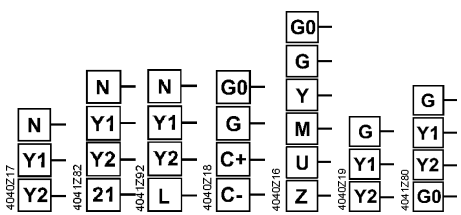
<p>1  No: 4</p>  <p style="text-align: right;">4041Z29</p>	<p>2  PZ 1</p>  <p style="text-align: right;">4041Z11</p>
<p>3</p>  <p style="text-align: right;">4041Z12</p>	<p>4</p>  <p style="text-align: right;">4041Z30</p>
<p>5</p>  <p style="text-align: right;">4041Z31</p>	<p>6 Observe "Connection terminals" (page 39)</p> 

Auxiliary switch ASC10.51

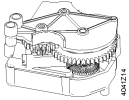

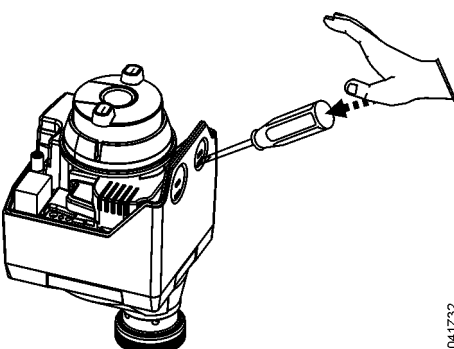
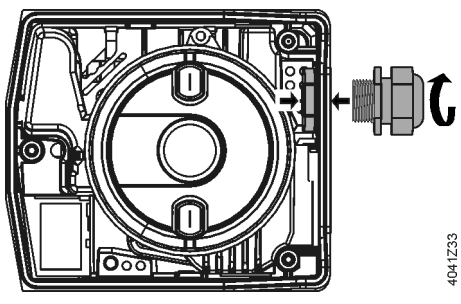
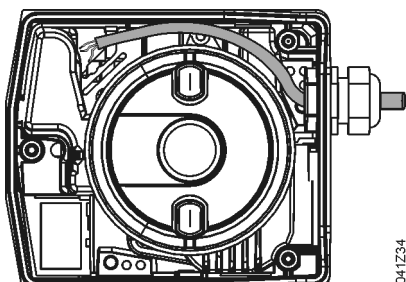
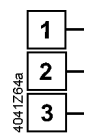
<p>1  No: 3</p>  <p style="text-align: right;">4041Z32</p>	<p>2</p>  <p style="text-align: right;">4041Z33</p>
<p>3</p>  <p style="text-align: right;">4041Z34</p>	<p>4 Observe "Connection terminals" (page 39)</p> 

3.2 Commissioning and operation

3.2.1 Function check and Calibration

Manually



Before making the function check, the following preconditions must be satisfied:

- "Environmental conditions" specified in chapter "Technical data" (page 36)
- Actuator is mechanically connected to a Siemens valve.
- **Actuator is in "Manual operation" mode** (page 33).

If available, the actuator can be operated with the help of the "Manual adjuster" (see page 33).

Manual adjuster	Stroke actuator	Control path valve A → AB	Bypass valve B → AB
Turning in clockwise direction	Actuator's stem extends	Opening	Closing
Turning in counter-clockwise direction	Actuator's stem retracts	Closing	Opening

Notes

- If the actuator is forced to travel beyond its end positions, overload protection responds.
- Observe information given in chapter 3.4.1 Positioning signal and flow characteristic selection, page 26.

Electrically



Before making the function check, the following preconditions must be satisfied:

- "Environmental conditions" specified in chapter "Technical data" (page 36).
- Actuator is mechanically connected to a Siemens valve.
- **Actuator is in "Automatic" mode** (page 33).
- Actuator and, if required, accessories are correctly fitted and connected. Also refer to chapter 5.2 Connection terminals (page 39).
- Power is applied.

SA..61..

Calibration is required with modulating actuators and SA..61.. before the function check.

General notes on calibration

Before making the calibration, the following preconditions must be satisfied:

- A description of the calibration function is given in chapter 3.4.3 Calibration (page 27).
- Housing cover is removed (see "Special notes on mounting", page 15).

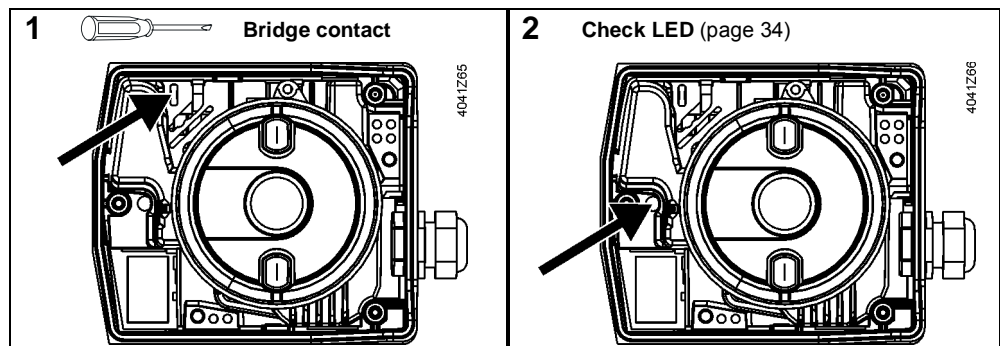

If required, calibration can be repeated any number of times.

Make the function check for modulating actuators after the calibration with a point test according to the following table:

Connection terminals	Stroke actuator	Control path valve A → AB	Bypass valve B → AB	Position feedback U
Y 6 V 13.6 mA	Actuator's stem extends (60%)	Opening	Closing	6 V
Y 5 V 12 mA	Actuator's stem retracts (50%)	Closing	Opening	5 V
Z connected to G	Actuator's stem extends	Opening	Closing	10 V
Z connected to G0	Actuator's stem retracts	Closing	Opening	0 V
Only SAS61.33, SAS61.33U, SAS61.53, SAT61.51 No voltage at G and G0 (fail safe function) ¹⁾	Actuator's stem retracts (until end position is reached)	Closing	Opening	-

¹⁾ Closing action is always completed first, also when power returns.

SA..31.. and SA..81..

Make the function check for 3-position actuators according to the following table:

Connection terminals	Stroke actuator	Control path valve A → AB	Bypass valve B → AB
Voltage at Y1	Actuator's stem extends	Opening	Closing
Voltage at Y2	Actuator's stem retracts	Closing	Opening
No voltage at Y1 and Y2	Actuator's stem maintains the position	Maintains the position	
Only SAS31.50, SAS31.53, SAS81.33, SAS81.33U, SAT31.51 No voltage at G and G0 (fail safe function) ¹⁾	Actuator's stem retracts (until end position is reached)	Closing	Opening

¹⁾ Closing action is always completed first, also when power returns.

Note

- Observe information given in chapter 3.4.1 Positioning signal and flow characteristic selection, page 26.

Auxiliary switch ASC10.51

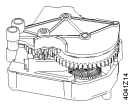

Make the function check of the mounted auxiliary switch with a point test according to the following table – example switching point at 25% position:

Connection terminals		Stroke actuator	Terminal S1 – S3	Terminal S1 – S2
Voltage at Y2	Y = 0 V	Actuator's stem retracts (until end position is reached)	-	-
No voltage at Y1 und Y2	Y = 0 V	Actuator's stem maintains the position		
Voltage at Y1 for desired valve position % + 2% x positioning time Example: SAS31.00 = 27 % x 120 sec = 32.5 sec	Valve position % + 2% Y = 2.7 V	Actuator's stem extends to desired position (27%)		
Check switching point with voltmeter		Actuator's stem maintains the position	-	-

3.2.2 Maintenance

The actuators are maintenance-free.

Mounting:

- Do not touch the valve coupling if the components (valve/pipes) are hot
- If necessary, disconnect electrical connections from the terminals

The actuator must be correctly fitted to the valve before recommissioning.

3.2.3 Disposal

The device is considered an electronics device for disposal in terms of European Directive 2012/19/EU and may not be disposed of as domestic garbage.

- Dispose of the device through channels provided for this purpose.
- Comply with all local and currently applicable laws and regulations.



3.3 3-position control

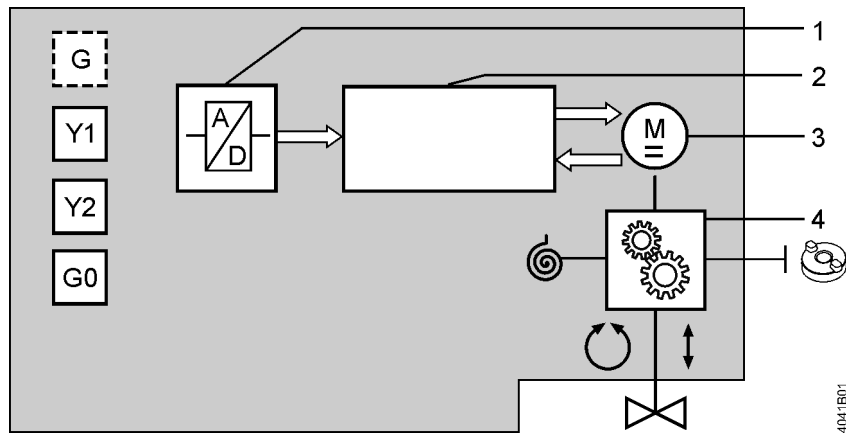

Example: brushless DC motor with fail safe function

A 3-position signal drives the actuator via connection terminals Y1 or Y2. The required position is transferred to the valve.

1	A/D conversion	
2	Control functions	Identification of seat
		Control of direction
		Motor control
		Manual adjustment
3	Brushless DC motor	
4	Gear train	
	Fail safe function	
	Manual adjuster	

Positioning signal	Stroke actuator	Control path valve A→AB	Bypass valve B → AB
Voltage at Y1	Actuator's stem extends	Opening	Closing
Voltage at Y2	Actuator's stem retracts	Closing	Opening
No voltage at Y1 and Y2	Actuator's stem maintains the position	Maintains the position	
No voltage at Y1 and Y2; with fail safe function	Actuator's stem retracts	Closing	Opening

Note

Observe information given in chapter 3.4.1 Positioning signal and flow characteristic selection on page 26.

Internal control ensures very constant positioning times and determination of the actuator's position.

Positioning times stroke model

The specified positioning times refer to the respective nominal stroke. Since the end positions of rotary actuators are inside the actuator, the following remarks refer to stroke actuators.
 The resulting effective strokes vary, depending on the type of valve, resulting in shorter or longer actuator positioning times.

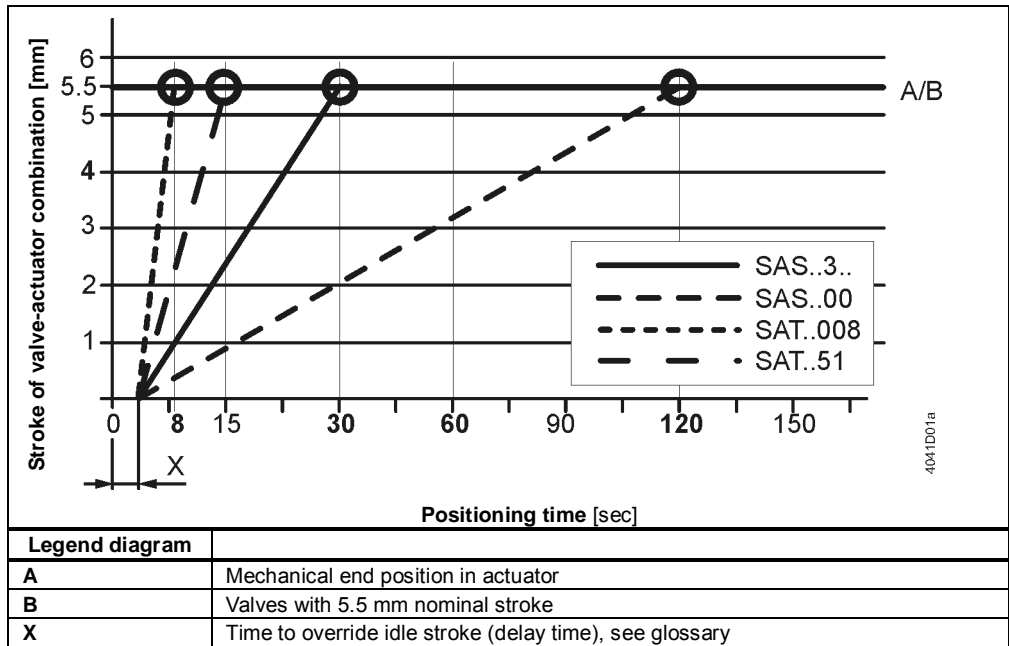

Notes

- Deviations occur
- after several positioning signals Y1 and Y2 in the same direction since the stroke movement starts with a delay of 50 ms.
 - when positioning signals Y1 and Y2 are active for less than 50 ms since the stroke movement cannot be made in that case.

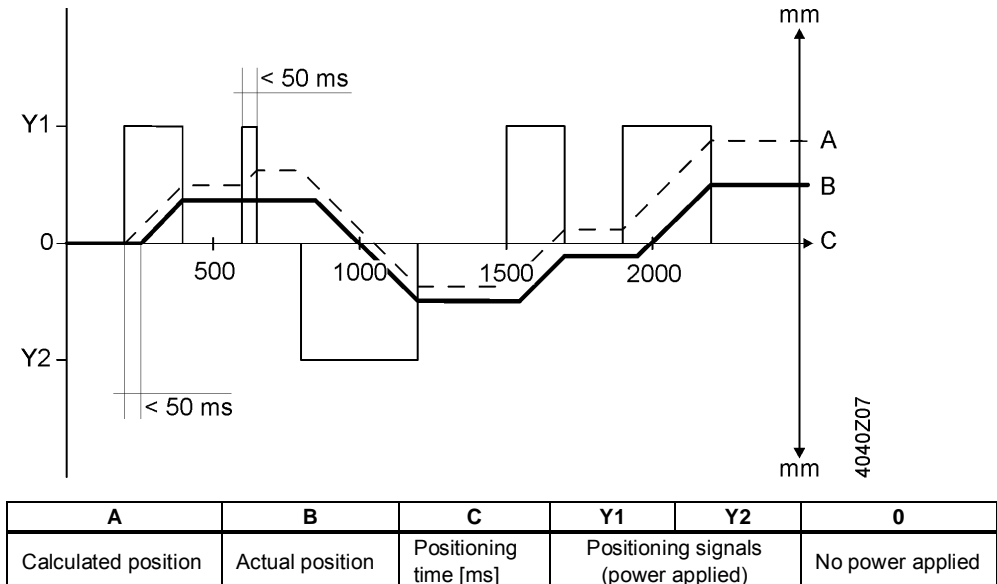

3.4 Modulating control

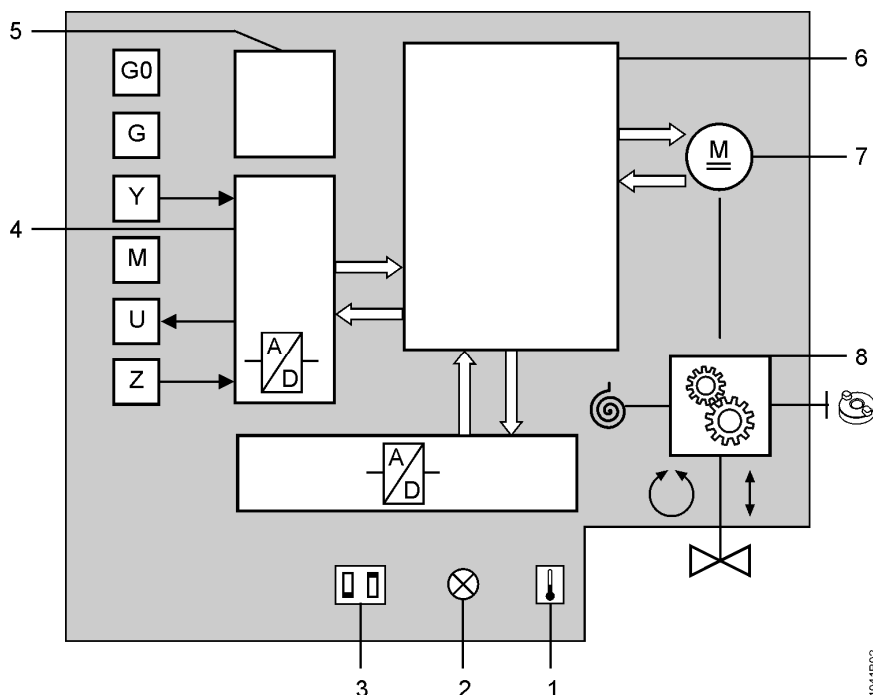

The modulating positioning signal drives the actuator steplessly. The positioning signal range (DC 0...10 V / DC 4...20 mA / 0...1000 Ω) corresponds in a linear manner to the positioning range (fully closed...fully open, or 0...100 % stroke).

The actuator is controlled via terminal Y or forced control Z (page 30). The desired stroke is transferred to the valve stem.

1	Calibration slot	
2	LED (2 colors)	
3	DIL switches	Changeover of characteristic
		Positioning signal
4	A/D conversion	
5	Power supply	
6	Control functions	Identification of seat
		Position control
		Motor control
		Detection of foreign bodies
		Calibration
		Forced control
		Characteristics function
Manual adjustment		
7	Brushless DC motor	
8	Gear train	
	Fail safe function	
	Manual adjuster	

Positioning signal	Stroke actuator	Control path valve A → AB	Bypass valve B → AB
Signal Y, Z increasing	Actuator's stem extends	Opening	Closing
Signal Y, Z decreasing	Actuator's stem retracts	Closing	Opening
Signal Y, Z constant	Actuator's stem maintains the position	Maintains the position	
No voltage at Y1 and Y2; with fail safe function	Actuator's stem retracts	Closing	Opening

Note



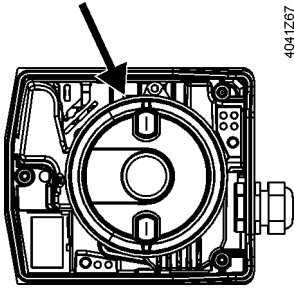

Observe the information given in chapter 3.4.1 Positioning signal and flow characteristic selection on page 26.

3.4.1 Positioning signal and flow characteristic selection

DIL switches



4041Z67

	Positioning signal "Y"	Position feedback "U"	Flow characteristic
ON	 4040Z09 DC 4...20 mA	DC 0...10 V	 4040Z11 lin = linear
OFF	 4040Z57 DC 0...10 V	DC 0...10 V	 4040Z58 log = equal-percentage

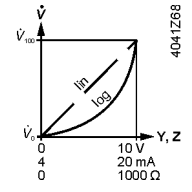

Note

¹⁾ Factory setting: All DIL switches set to OFF

Factory setting SAS..:

- Characteristic curve : log = Equal percentage (switch at "OFF")
- Positioning signal: DC 0...10 V (switch at "OFF")

Factory setting SAT..:

- Characteristic curve: lin = linear (switch at "ON")
- Positioning signal: DC 0...10 V (switch at "OFF")

Flow characteristic

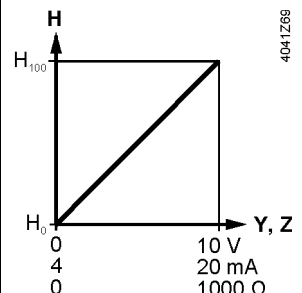
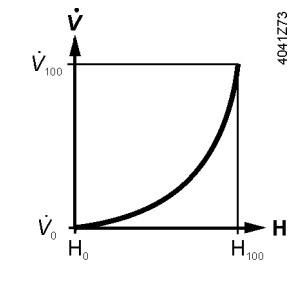
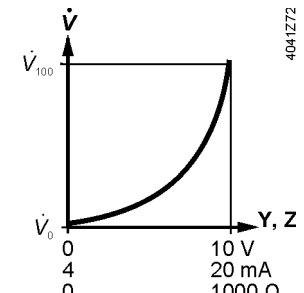
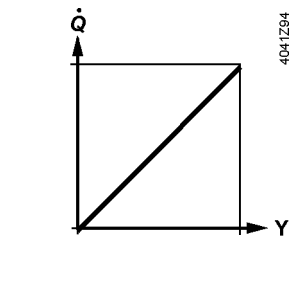
Actuator SAT..	Valve VVG55.. / VVG549..	Valve & actuator combined	Valve & actuator & heat exchanger combined
 4041Z68	 4041Z73	 4041Z72	 4041Z94

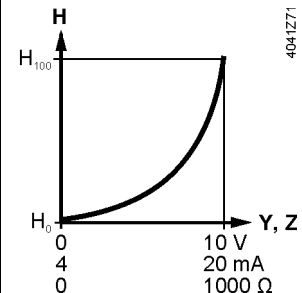
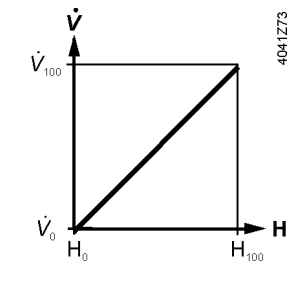
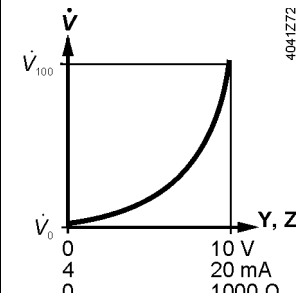
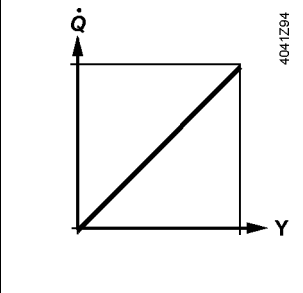
Actuator SAS..	Valve VVG44.. / VVG44..	Valve & actuator combined	Valve & actuator & heat exchanger combined
 4041Z71	 4041Z73	 4041Z72	 4041Z94

Y, Z Positioning signal
H Stroke
 \dot{V} Volumetric flow
 \dot{Q} Heat transfer capacity

3.4.2 Position feedback U

The position feedback U (DC 0...10 V) is always proportional to stroke H of the actuator's stem.

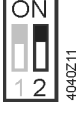
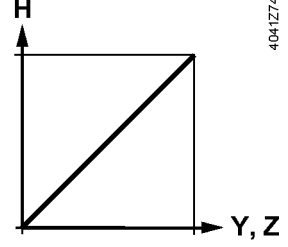
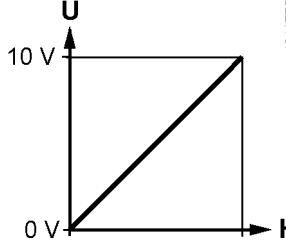
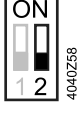
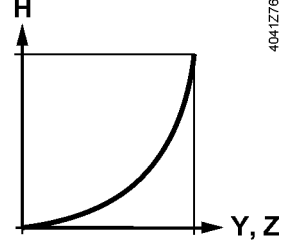
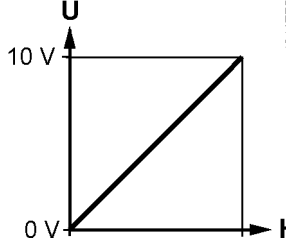
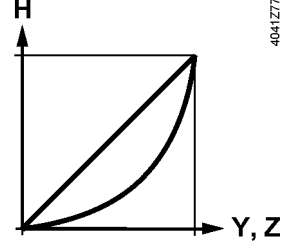
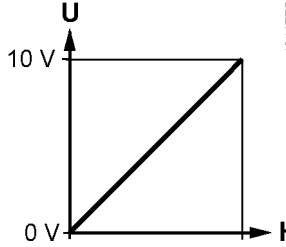
	Actuator Positioning signal Y, Z	Actuator Position feedback U						
 lin = linear	 4041Z74	 4041Z75						
 log = equal-percentage	 4041Z76	 4041Z75						
<table border="1"> <tr> <td>Y, Z</td> <td>Positioning signal</td> </tr> <tr> <td>H</td> <td>Stroke</td> </tr> <tr> <td>U</td> <td>Position feedback</td> </tr> </table>	Y, Z	Positioning signal	H	Stroke	U	Position feedback	 4041Z77	 4041Z75
Y, Z	Positioning signal							
H	Stroke							
U	Position feedback							

3.4.3 Calibration

To match the actuator to production-related mechanical tolerances of the individual valves and to guarantee accurate positioning and position feedback, a calibration should be performed when the plant is commissioned (page 20). During commissioning, the actuator detects the valve's end positions and files the exact stroke in its internal memory.

Calibration takes place in the following phases:

- Actuator drives to the upper end position (1), valve closes. Detection of upper end position.
- Actuator drives to the lower end position (2), valve opens. Detection of lower end position.
- The detected values are stored (3). Then the actuator follows the positioning signal.

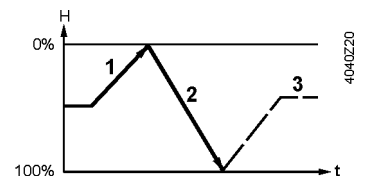

Note

Observe status indication (LED) during and after calibration (page 34).

3.4.4 Signal priorities

The actuators are controlled via different interlinked positioning signal paths (positioning signal "Y", forced control input "Z", manual adjuster). The signal paths are assigned the following priorities (1 = highest priority, 4 = lowest priority):

Actuator without fail safe function



Priority	Description	
1	The manual adjuster always has priority 1, thus overriding all signals active at "Z" or "Y", independent of whether or not power is applied.	
2	Only SA..61..: As soon as a valid positioning signal is active at input "Z", the position is determined via positioning signal "Z" (forced control). Prerequisite: The manual adjuster is not used.	Z
3	The position is determined via positioning signal "Y" at Y, Y1 or Y2. The manual adjuster is not used and on "Z" there is no active signal.	Y

Examples

Manual adjuster	Forced control (Z)	Positioning signal (Y)	Stroke actuator	Rotary actuator
Automatic mode	Not connected	5 V	Actuator's stem travels to position (50%)	Actuator's spindle travels to position (50%)
Automatic mode	G	3 V	Actuator's stem extends	Actuator's spindle turns in clockwise direction
Automatic mode	G0	3 V	Actuator's stem retracts	Actuator's spindle turns in counterclockwise direction
Operated (30%) and engaged	G	8 V	Actuator's stem extends manual (to 30%)	Actuator's spindle turns manually in counterclockwise direction (to 30%)

Bold printing = positioning signal currently active

Actuator with fail safe function

Priority	Description	
1	The fail safe function responds in the event of a power failure.	
2	The position is solely determined via positioning signal "Z" (forced control), provided power is applied.	Z
3	The position is determined by positioning signal Y, provided power is applied and positioning signal "Z" is not used.	Y
4	Upon actuation and slightly turning in counterclockwise direction, the manual adjuster remains engaged. Power applied: After 5 seconds, the manual adjuster disengages itself and positioning signal "Y" or "Z" determines the position. No power applied: The actuator maintains the position defined by the manual adjuster until power returns. Upon restoration of power, an automatic ClosedPosition-Synchronisation will be performed.	

Examples

Operating voltage (G/G0)	Manual adjuster	Forced control (Z)	Positioning signal (Y)	Stroke actuator
Applied	Automatic mode	Not connected	5 V	Actuator's stem travels to position (50%)
Applied	Automatic mode	G	3 V	Actuator's stem extends
Applied	Automatic mode	G0	3 V	Actuator's stem retracts
Interrupted (fail safe function)	Automatic mode	G	6 V	Actuator's stem retracts (until end position is reached)
Interrupted (fail safe function)	Operated (30%) and engaged	G	8 V	Actuator's stem retracts (until end position is reached), then: Actuator's stem extends manually (to 30%)

Bold printing = positioning signal currently active

3.4.5 Detection of valve seat

SAS..

The actuators feature force-dependent valve seat detection. After calibration, the exact valve stroke is filed in the actuator's memory. If no force is built up in the calculated end position (e.g. in the event of temperature effects for instance), the actuator continues to operate at a reduced positioning speed until the nominal positioning force is restored. This ensures that the valve always fully closes.

After a power failure, valve seat identification is not active – the actuators without fail safe function define their stroke position on power resoration to be at 50%. From now on, the actuator follows the positioning signal.

When the valve plug reaches its seat for the first time, the actuator readjusts its stroke model.

Example

The supposed position is 50%, $Y = 2\text{ V}$, the actuator travels 30% of the stored valve stroke in the direction of "Actuator's stem retracted".

If the actuator reaches the seat within this 30% travel, it interprets the position as "Valve fully closed" and shifts the position of the valve's stroke accordingly without changing the extent of travel.

From now on, the actuator follows the changed valve stroke position.

This means: New position 0%, $Y = 2\text{ V}$, actuator travels 20% of the stored valve stroke in the direction "Actuator's stem extended".

3.4.6 Detection of foreign bodies

The actuator detects when the valve is clogged and adjusts its operational behavior accordingly to prevent damage to itself or the valve.

If the actuator hits an obstacle within the calibrated stroke and is not able to overcome it with its nominal positioning force, it stores the position at which the obstacle was hit. Depending on the direction of travel, as ...

"Upper limit of valve clogging", if the clogging was detected when traveling in the direction of "Actuator's stem extending".

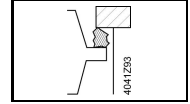

Now, the status LED blinks red and the actuator only follows the positioning signal between the positions "Actuator's stem retracted" and "Lower limit of valve clogging".

After detection of clogging, 3 attempts are made to overcome clogging by traveling about 15% in the opposite direction and then trying again to overcome the position of clogging. If the attempts made are unsuccessful, the actuator continues to follow the positioning signal within the restricted range only and the LED continues to blink red (see "Status indication " page 34).

3.4.7 Forced control Z

Forced control uses the following operating modes:

		Z mode			
		No function	Fully open	Fully closed	Overriding positioning signal "Y" by 0...1000 Ω
Connections					
	Transmission				
		Equal-percentage or linear characteristic			Equal-percentage or linear characteristic
		Contact "Z" not connected, valve follows positioning signal "Y"	Contact "Z" is connected directly to "G", positioning signal "Y" has no impact	Contact "Z" is connected directly to "G0", positioning signal "Y" has no impact	Contact "Z" is connected to "M" via resistor "R", starting point at 50 Ω, end point at 900 Ω, positioning signal "Y" has no impact

3.5 Technical and mechanical design

3.5.1 Transmission of power

Function principle

Incoming positioning signals are translated to positioning commands for the motor.

A gear train transmits the motor's positioning steps to the output stage. Here, the translation from rotary to stroke movement takes place. Attached to the gear train are the electrical and mechanical accessory items and the manual adjuster. With the stroke actuators with fail safe function, the gear train also accommodates the return spring.

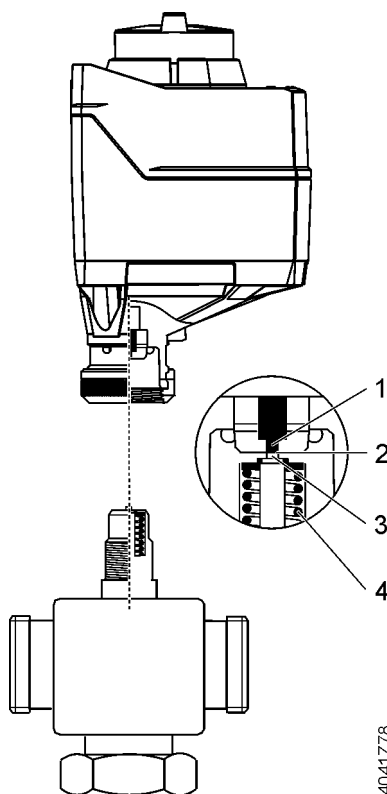

Power transmission of stroke actuator:

- 1 Actuator stem
- 2 Contact point
actuator stem – valve stem
- 3 Valve stem
- 4 Valve spring

The transmission of power has no fix connection.

If the actuator stem extends, it presses on the valve stem and against the force of the spring in the valve.

If the actuator stem retracts, the valve stem follows the actuator stem due to the force of the valve spring.

3.5.2 Coupling

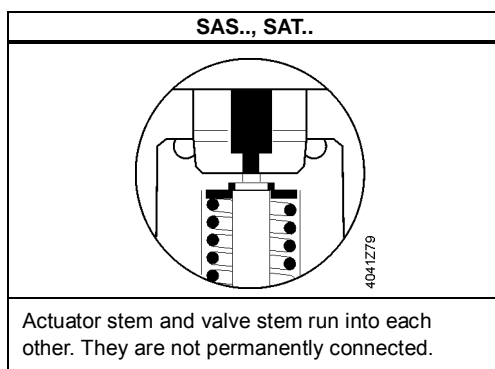

3.5.3 Fail safe function

The fail safe function works mechanically with a return spring and ensures the protection of the plant. It guarantees the safe operation in uncontrolled operating states.

In the event of a power failure, the actuator will return to its 0 % stroke position with the help of the return spring, closing the valve. The Y positioning signal is not valued.

Fail safe function	Actuator	Valve		Spring return time	At positioning time
Active	Actuator's stem retracts	Spring in valve closes	Valve closes	<8 s ¹⁾ <14 s ¹⁾ <28 s ¹⁾	15 s 30 s 120 s

¹⁾ Spring return time increased slightly at low temperatures

3.5.4 Manual adjuster

Automatic

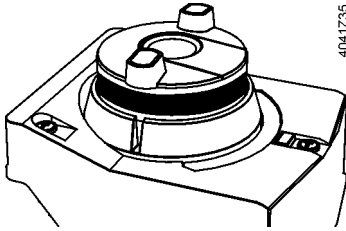
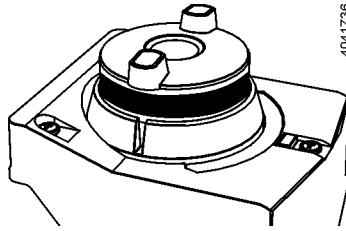
Without fail safe function	With fail safe function (SA..33..)
	

When the motor drives the manual adjuster turns. Thus in automatic mode, the manual adjuster is used for indication of travel. If the manual adjuster is held firm in this mode, there is no transmission of power to the gear train.

Manual operation

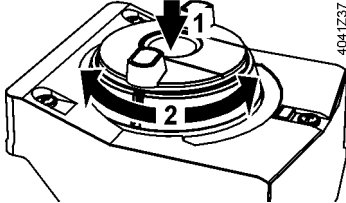
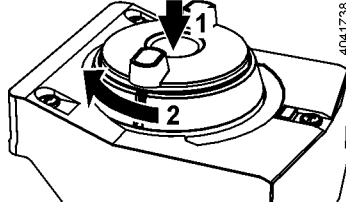
	
---	---

When pushing the manual adjuster down (1), it engages and the actuator can be manually operated.

Stroke actuator: When turning the manual adjuster in clockwise / counterclockwise direction (2), the actuator's stem extends / retracts.

Rotary actuator: The actuator spindle turns in the same direction

When turning the manual adjuster in clockwise direction (2), the actuator's stem extends.

CAUTION: Turning the manual adjuster in counterclockwise direction is not possible.

An overload protection prevents damage to the manual adjuster.

Fixing the position

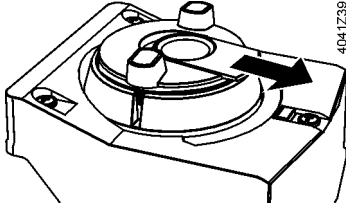
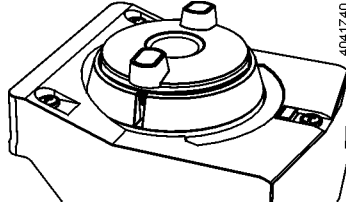
	
---	---

Upon actuation and locking the slide switch, the manual adjuster remains engaged.

When in this mode, do not turn the manual adjuster (manual adjuster locked).

After pushing and slightly turning the manual adjuster in counterclockwise direction, it remains engaged, provided no power is applied.

If power is applied, refer to "Disengaging the fixing".

Disengaging the fixing

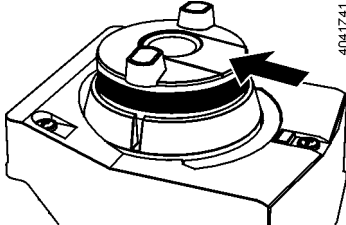
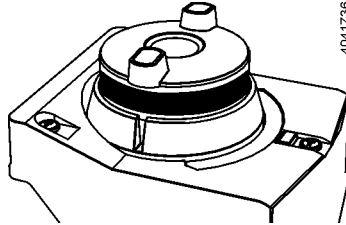
	
---	---

When resetting the slide switch, the manual adjuster returns to automatic mode.

Coupling disengages **automatically**...

- after 5 seconds if power is applied,
- when power returns; a restart is made (actuator's stem retracts), then, the actuator follows the active positioning signal.

Coupling is disengaged **manually** by slightly turning the manual adjuster in clockwise direction.

3.5.5 Indicators

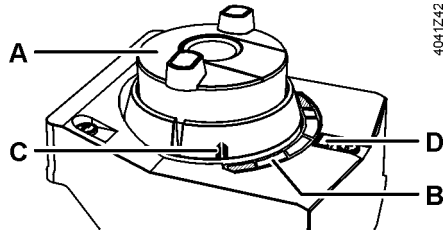

A	Indication of travel	
B	Scale	Position indication
C	Indicator	
D	LED Status indication	

Operational status indication

In Automatic mode, the manual adjuster serves for the indication of travel. See "Automatic" (page 33).

Position indication

When turning the manual adjuster, the indicator also moves. The scale indicates the stroke. When reaching the stops, the valve is either fully open or fully closed.

Status indication (LED), only with modulating control (only SA..61..)

Housing cover fitted	Housing cover removed
When the housing cover is fitted, the LED can be viewed through a light conductor.	When the housing cover is removed, the LED can be viewed through a hole.

The status indication informs about the operational state of the actuator.

LED	Indication	Operating state	Remarks, troubleshooting
Green	On	Automatic mode	Normal operation
	Blinking	Calibration	Wait until calibration is finished (then green or red light)
		In manual mode	Manual adjuster in MAN position
Red	On	Calibration error	Start calibration again
		Undervoltage (AC 13 V)	Check operating voltage
	Blinking	Clogged valve, detection of foreign bodies	Check valve / actuator
Dark	Dark	No power or electronics faulty	Check operating voltage

3.5.6 Electrical accessories

Auxiliary switch ASC10.51

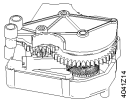

AC 24 V...230 V / 6 (3) A

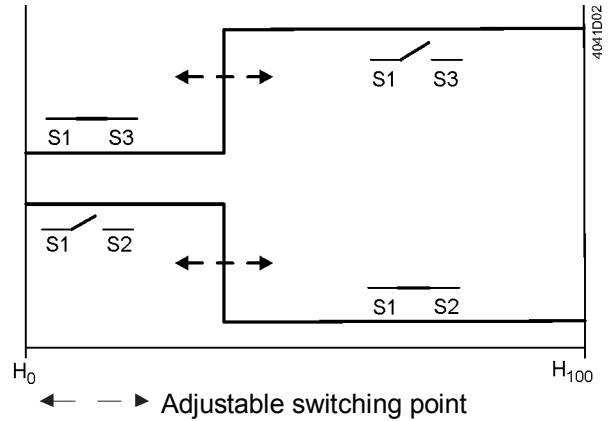
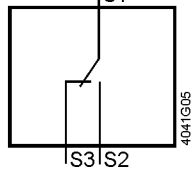

Switching point for S1–S2 and S1–S3 cannot be set separately. If S1–S2 is open then S1–S3 is closed.

Application example:

When using an auxiliary switch, position feedback can trigger an automatic stop of the circulating pump in the end position "Fully closed".

3.5.7 Mechanical accessories

Weather shield ASK39.2

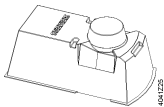

To protect the actuator from weather effects when used outdoors, the weather shield ASK39.2 must always be fitted. The housing protection IP54 remains unchanged. See also page 14.

4 Technical data

		SAS..	SAT..	
Power supply	Operating voltage	SA..31..	AC 230 V ± 15 %	
		SA..61..	AC 24 V ± 20 % / DC 24 V + 20 % / -15% or AC 24 V class 2 (US)	
		SA..81..	AC/DC 24 V ± 20 % or AC 24 V class 2 (US)	
	Frequency	45...65 Hz		
	External supply line protection (EU)	6 A...10 A slow or Circuit breaker max. 13 A Characteristic B, C, D according to EN 60898 Power source with current limitation of max. 10 A		
	Power consumption at 50 Hz	Stem retracts / extends	Stem retracts / extends	
	SAS31.00 SAT31.008	2.8 / 2.4 VA ¹⁾	5.0 / 2.5 VA ¹⁾	
	SAS31.03 SAT31.51	3.5 / 2.9 VA ¹⁾	5.5 / 3.2 VA ¹⁾	
	SAS31.50 SAT61.008	3.5 / 2.9 VA ¹⁾	7.1 / 4.6 VA ¹⁾	
	SAS31.53 SAT61.51	5.5 / 3.8 VA ¹⁾	6.4 / 4.8 VA ¹⁾	
	SAS61.03	5.3 / 4.5 VA ¹⁾		
	SAS61.03U	5.3 / 4.5 VA ¹⁾		
	SAS61.33	5.9 / 4.8 VA ¹⁾		
	SAS61.33U	5.9 / 4.8 VA ¹⁾		
	SAS61.53	5.8 / 5.0 VA ¹⁾		
	SAS81.00	2.2 / 2.0 VA ¹⁾		
SAS81.03	2.5 / 2.1 VA ¹⁾			
SAS81.03U	2.5 / 2.1 VA ¹⁾			
SAS81.33	3.4 / 2.4 VA ¹⁾			
SAS81.33U	3.4 / 2.4 VA ¹⁾			
Function data	Positioning times with the specified nominal stroke			
	SAS..0 SAT..008	120 s		8 s
	SAS..3/..3U SAT..51	30 s	15 s	
	Positioning force	400 N	300 N	
	Nominal stroke	5.5 mm	5.5 mm	
	Permissible medium temperature (valve fitted)	1...130 °C	1...130 °C	
	briefly	150 °C (up to 150 °C max. 6 of 24 hours)		
Signal inputs	Y positioning signal			
	SAS31.. SAT31.008	3-position	DC 0...10 V / DC 4...20 mA / 0...1000 Ω	
	SAS81.. SAT31.51			
	SAS61.. SAT61.008 SAT61.51			
	SA..61.. (DC 0...10 V) Current draw	≤ 0.1 mA		
	Input impedance	≥ 100 kΩ		
	SA..61.. (DC 4...20 mA) Current draw	DC 4...20 mA ± 1 %		
Input impedance	≤ 500 Ω			
Parallel operation	SA..61..	≤ 10 (depending on controller output)		
Forced control	Positioning signal Z	SA..61..	R = 0...1000 Ω, G, G0	
		R = 0...1000 Ω	Stroke proportional to R	
	Z connected to G	Max. stroke 100 %	Max. stroke 100 %	
	Z connected to G0	Min. stroke 0 %	Min. stroke 0 %	
	Voltage	Max. AC 24 V ± 20 % / Max. DC 24 V + 20 % / -15%		
	Current draw	≤ 0.1 mA		
Position feedback	U	SA..61..	DC 0...10 V ± 1 %	
		Load impedance	> 10 kΩ res.	
		Load	Max. 1 mA	
Connecting cable	Wire cross-sectional areas	0.75...1.5 mm ² , AWG 20...16 ²⁾		
	Cable entries	SA..	EU: 1 entry Ø 16.4 mm (for M16) 1 entry Ø 20.5 mm (for M20)	
		SA..U	US: 2 entries Ø 21.5 mm for ½" tube connection	

		SAS..	SAT..
Degree of protection	Housing protection	IP 54 as per EN 60529	
	Insulation class	As per EN 60730	
	Actuators SA..31.. AC 230 V	II	
	Actuators SA..61.. AC / DC 24 V	III	
	Actuators SA..81.. AC / DC 24 V	III	
Environmental conditions	Operation	IEC 60721-3-3	
	Climatic conditions	Class 3K5	
	Mounting location	Indoors, outdoors ³⁾	
	Temperature general	-5...55 °C	
	Humidity (noncondensing)	5...95 % r. h.	
	Transport	IEC 60721-3-2	
	Climatic conditions	Class 2K3	
	Temperature	-25...70 °C	
	Humidity	<95 % r. h.	
	Storage	IEC 60721-3-1	
	Temperature	-15...55 °C	
	Humidity	5...95 % r. h.	
Directives and Standards	Product standard	EN60730-x	
	Electromagnetic compatibility (Application)	For residential, commercial and industrial environments	
	EU Conformity (CE)	SAS.: CE1T4581xx ⁴⁾ SAT.: CE1T4584xx ⁴⁾	
	RCM Conformity	SAS.: CE1T4581en_C1 ⁴⁾ SAT.: CE1T4584en_C1 ⁴⁾	
	UL, cUL AC / DC 24 V	UL 873 http://ul.com/database	
	EAC compliance	Eurasia compliance for all SA..-variants	
Environmental compatibility		The product environmental declaration CE1E4581 ⁵⁾ contains data on environmentally compatible product design and assessments (RoHS compliance, materials composition, packaging, environmental benefit, disposal).	
Dimensions		See Dimensions (page 42)	
Weight	Excl. packaging	See Dimensions (page 42)	
Accessories⁵⁾	Auxiliary switch Switching capacity	AC 24...230 V, 6 (2) A, floating	
	External supply line protection	See section power supply	
	US installation, UL & cUL	AC 24 V class 2, 5 A general purpose	
Data sheet		N4581	N4584

¹⁾ Second value: Power consumption in neutral position

²⁾ AWG = American wire gauge

Wire cross-sectional areas and fuses have to be well-matching, which is the responsibility of the planner / installer. Observe norm of protection measures - protection against overcurrent: IEC 60364-4-43:2008 resp. german adoption HD 60364-4-43:2010.

³⁾ Outdoors always with weather shield ASK39.2, housing protection IP54 remains unchanged

⁴⁾ The documents can be downloaded from <http://siemens.com/bt/download>

⁵⁾ UL recognized component 

5 Connection diagrams and dimensions

5.1 Internal diagrams

SA..31..

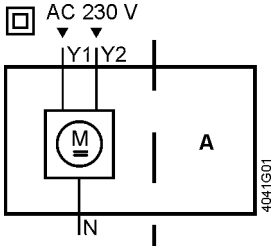

SA..31.5..

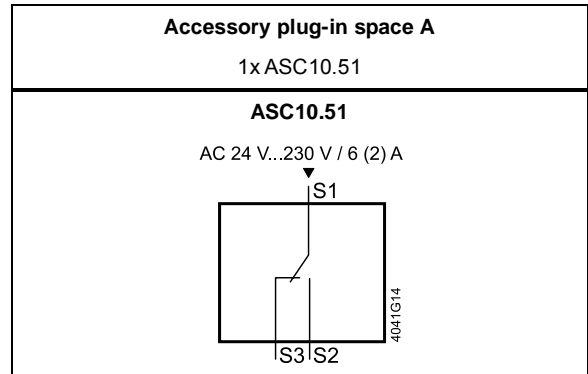
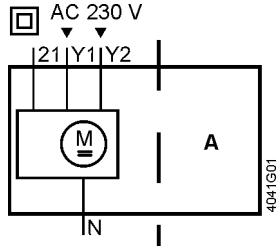

SA..61..

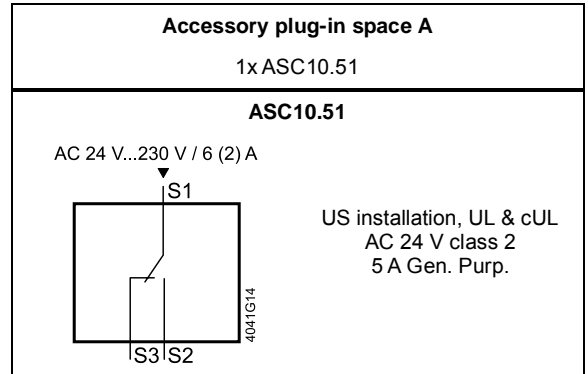
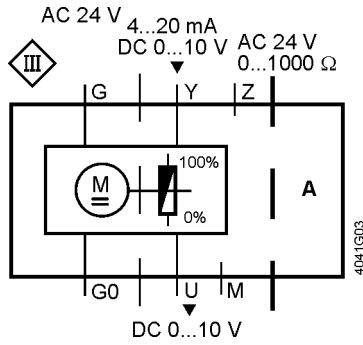

SAS81..

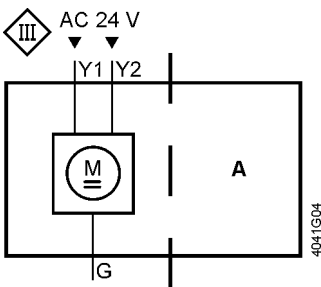

SAS81.33, SAS81.33U

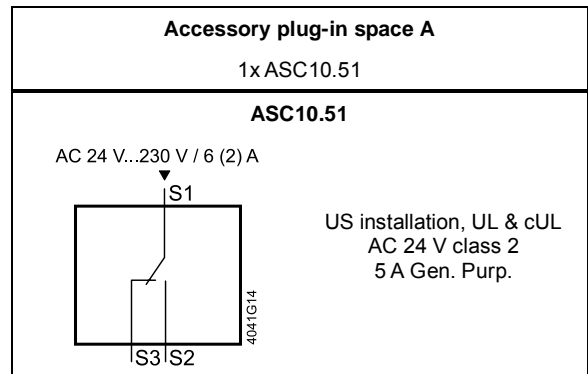
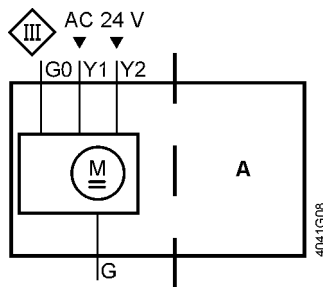

SAT31.008

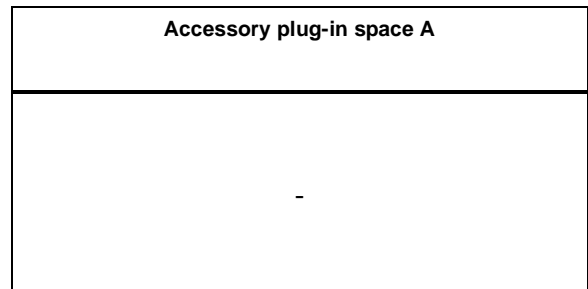
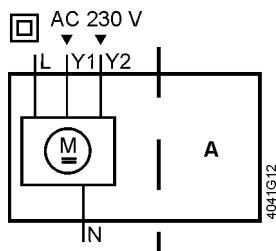

5.2 Connection terminals

5.2.1 Actuators

SA..31..
(without SAT31.008)

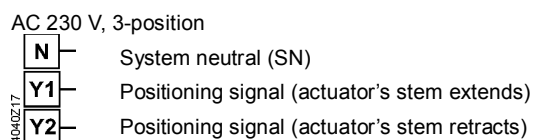

SA..31.5..

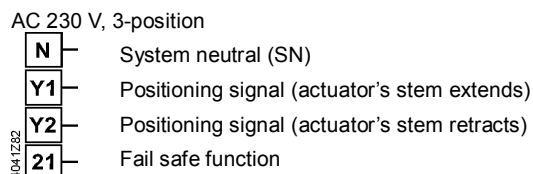

SA..61..

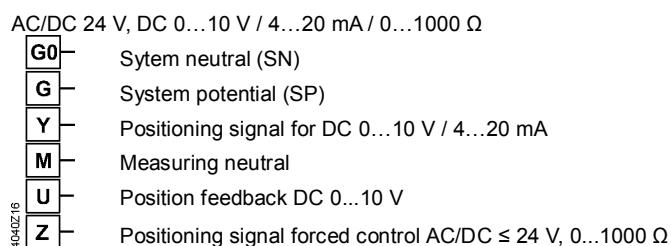

SA..81..

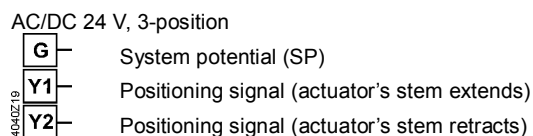

SAS81.33U

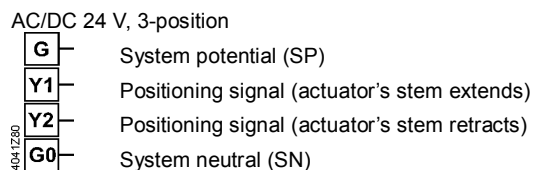

SAT31.008

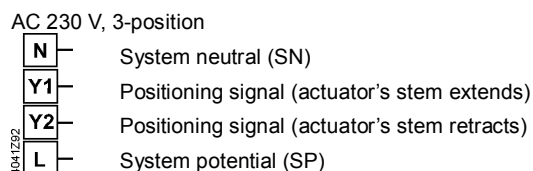

5.2.2 Electrical accessories

Auxiliary switch ASC10.51

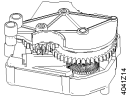

Adjustable switching points, AC 24...230 V

- 1 System potential (SP)
- 2 Closing (actuator's stem extends)
- 3 Opening (actuator's stem extends)

AC 24 V...230 V / 6 (2) A

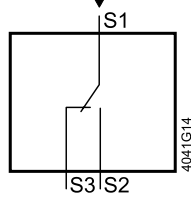

5.2.3 Cable labeling

The wires are color coded and labeled.

Connection	Cable				Description
	Code	No.	Color	Abbreviation	
Actuators AC 230V	N	4	blue	BU	System neutral
	Y1	6	black	BK	Positioning signal
	Y2	7	white	WH	Positioning signal
	L		-		System potential
	Z1		-		Fail safe function
Actuators AC 24 V resp. AC/DC 24 V	G	1	red	RD	System potential
	G0	2	black	BK	System neutral
	Y1	6	violet	VT	Positioning signal
	Y2	7	orange	OG	Positioning signal
	Y	8	grey	GY	Positioning signal
	M		-	-	Measuring neutral
	U	9	pink	PK	Position feedback
	Z		-	-	Positioning signal forced control

5.3 Connection diagrams

SA..31..

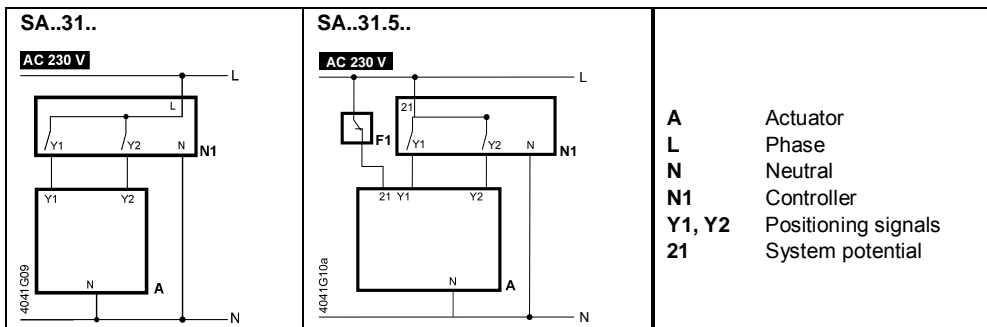

SA..61..

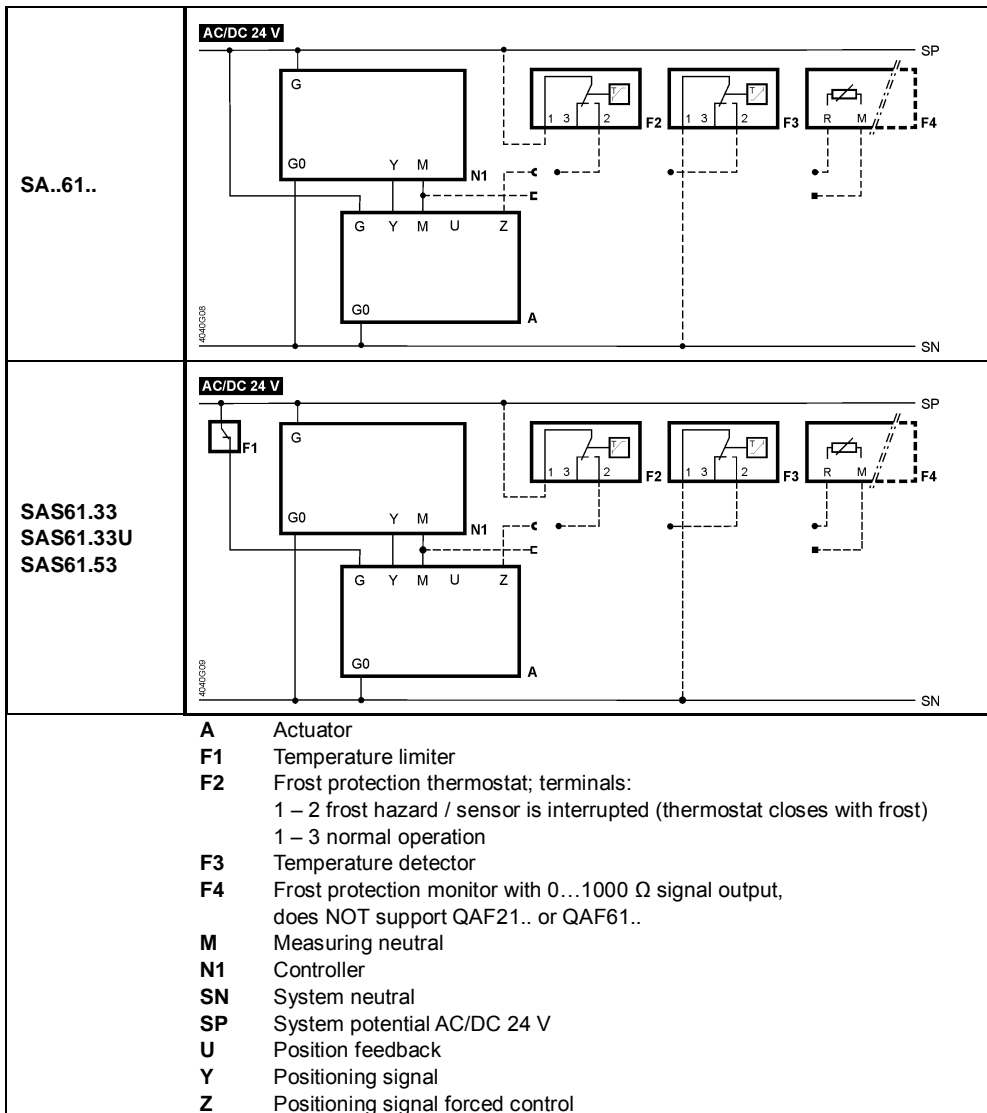

SA..81..

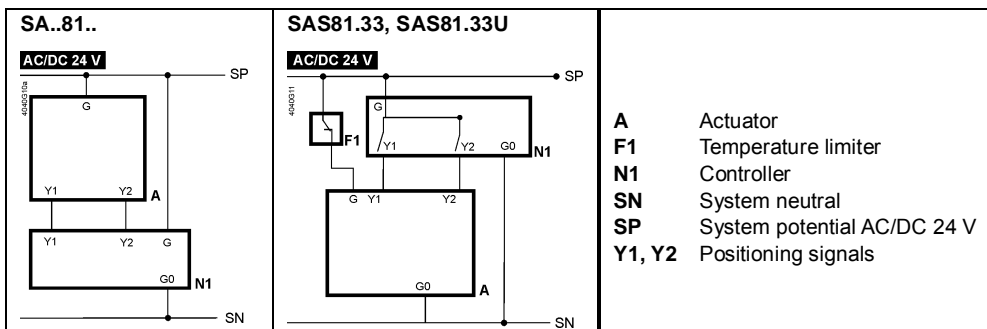

5.4 Dimensions

5.4.1 Stroke actuators

Dimensions in mm, weights in kg

With manual adjuster

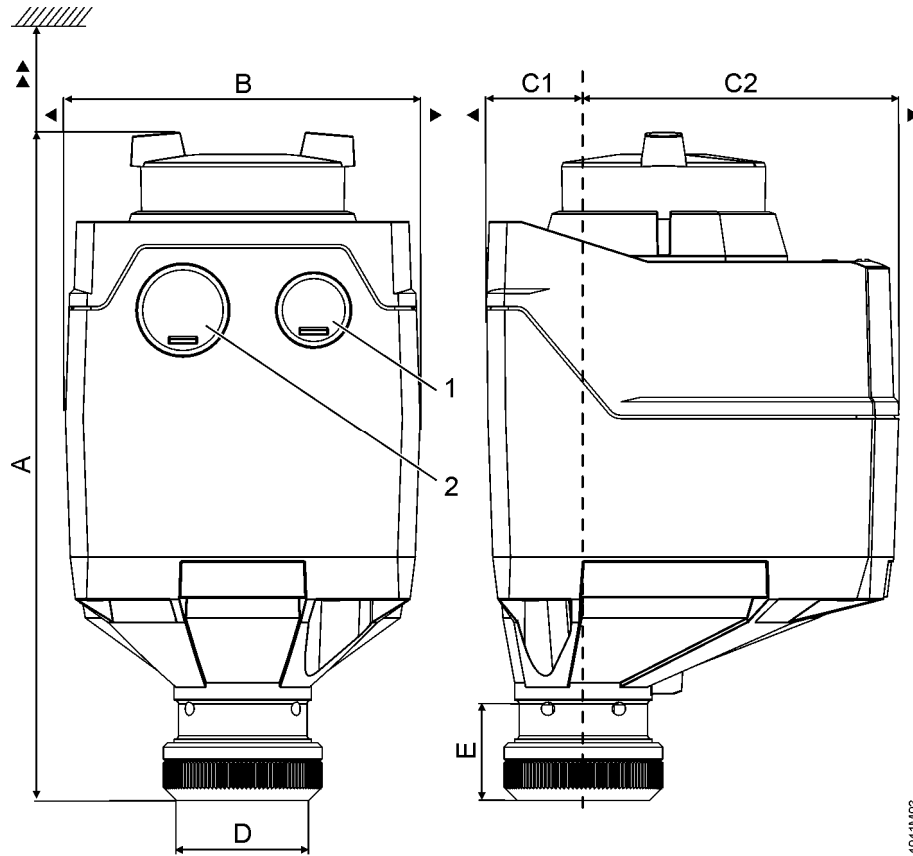

- 1 SA.: M16
SA..U: ½" (Ø 21.5 mm)
2 SA.: M20
SA..U: ½" (Ø 21.5 mm)

Product no.	A	B	C	C1	C2	D	E	▶	▶▶	kg
SAS.. / SAT..	151	80	93	21.9	71.1	29.9	21.8	100	200	0.40
With ASK39.2	155	126	248	99	149	29.9	21.8	100	200	0.55

4041M03

Without manual adjuster

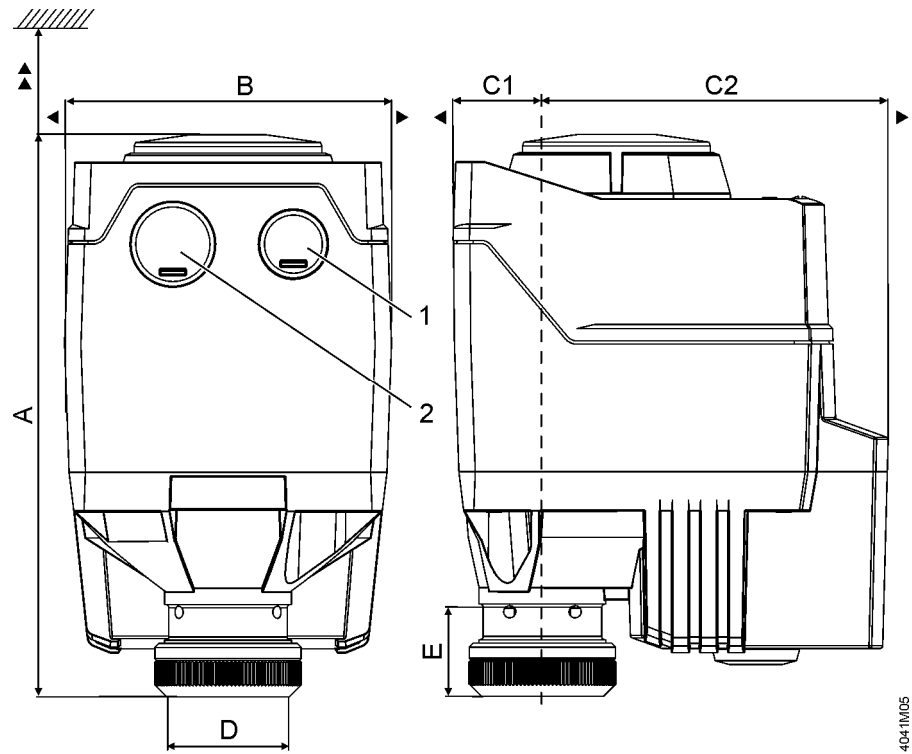

4041M05

- 1 SA... M16
- 2 SA... M20

Product no.	A	B	C	C1	C2	D	E	▶	▶▶	kg
SAT.. / SAT..	137.6 ¹⁾ 151 ²⁾	80	106.5	21.9	84.6	29.9	21.8	100	200	0.68
With ASK39.2	155	126	248	99	149	29.9	21.8	100	200	0.83

¹⁾ Black cover
²⁾ Blue manual adjuster

Revision numbers

Product no.	Valid from rev. no.	Product no.	Valid from rev. no.	Product no.	Valid from rev. no.
SAS31.00	..B	SAT31.008	..B		
SAS31.03	..B	SAT31.51	..B		
SAS31.50	..B	SAT61.008	..B		
SAS31.53	..B	SAT61.51	..B		
SAS61.03	..B				
SAS61.03U	..B				
SAS61.33	..B				
SAS61.33U	..B				
SAS61.53	..B				
SAS81.00	..B				
SAS81.03	..B				
SAS81.03U	..B				
SAS81.33	..B				
SAS81.33U	..B				

6 Glossary

6.1 Symbols



Caution, general danger – read the notes!



Caution, hot surface – read the notes!

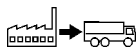

Condition as supplied to customer



Crosstip screwdriver (Pozidriv)

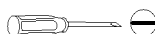

Slotted screwdriver



Screw wrench



Allen key

6.2 Terms

ClosedPosition-Synchronisation

The Synchronisation of the mechanical position and the internal position control will be performed (after manual operation).

DIL switches

A DIL switch shows the switching choices in the form of a place value system (dual in line) in relation to basis 2 (on and off).

DN

Nominal size [mm]: Characteristic for matching parts of the piping system.

Fail safe function

The fail safe function ensures that the actuator is driven to a defined end position also in the event of a power failure. In normal situations, dampers are shut or valves closed, thus cutting off the medium flow.

kPa

Unit of pressure: 100 kPa = 1 bar = 10 mWS.

k_{vs}

Nominal flow rate: Nominal flow rate of cold water (5...30 °C) through the fully open valve (H_{100}) at a differential pressure of 100 kPa (1 bar).

LED

Light emitting diode.

Idle stroke

The actuator stem lifts off the valve stem slightly (0.2 mm), so that the valve closed securely. If the valve opens again, this idle stroke has to be overcome, before the valve really opens (valve characteristic has an effect).

PN

PN class [bar]: Characteristic relating to the combination of mechanical and dimensional properties of a component in the piping system.

Position feedback

Signal used to acquire the position, fed back via an input.

Forced control

Forced control serves for overriding automatic mode and is implemented in the structure.

$\Delta p_{\max} / \Delta p_{\max V}$

Maximum permissible differential pressure across the valve's control path, valid for the entire actuating range of the motorized valve (V = diverting mode).

Δp_s

Maximum permissible differential pressure at which the motorized valve will close securely against the pressure (close off pressure).

Index

3-position control.....	23	Foreign bodies.....	30
A/D conversion	23, 25	Formulas for wire lengths.....	13
About this documentation.....	5	Function check.....	20
Accessories	10	Function principle	31
Electrical accessories	10	Functions.....	23
Mechanical accessories.....	10	Gear train	23, 25
Automatic operation	33	Glossary.....	45
Auxiliary switch	16, 19, 21, 35, 40	Handling.....	14
Before you start	5	Housing cover	11
Brushless DC motor	23, 25	Housing of spring return.....	7
Cable entries	18	HVAC plants.....	6
Cable glands	18	Identification of seat.....	23, 25
Cable labeling	40	Indicators.....	34
Calibration.....	20, 25, 27	Indoor use.....	14
Calibration slot.....	25	Installation	14
Changeover of characteristic	25	Interior view	15
Characteristics function	25	Internal diagrams.....	38
Commissioning.....	20	L/P-diagram	13
Connection diagrams	38, 41	LED.....	25
Connection terminal	39	Maintenance	22
Actuator.....	39	Manual adjuster	7, 8, 23, 25, 33
Electrical accessories	40	Manual operation.....	33
Contents.....	3	Mechanical accessories.....	35
Control.....	23	Mechanical design.....	31
Control functions.....	23, 25	Modulating control	25
Control of direction.....	23	Motor control	23, 25
Copyright	6	Mounting.....	14
Coupling.....	31	Mounting positions	14
Cross-sectional area.....	13	Navigation.....	5
Delivery	8	Operating voltage.....	8, 13
Detection of foreign bodies.....	25, 30	Operation	20
Detection of valve seat	29	Operational status	34
Deviations	24	Ordering.....	8
DIL switch.....	25, 26	Outdoor use.....	14
Dimensions	42	Parallel operation	12
Stroke actuators	42	Permissible cable length.....	12
Disposal	22	Permissible voltage drop	13
Document use.....	6	Permissible wire length.....	13
Electrical accessories.....	35	Plug-in space	16
Electrical connections.....	7	Position control	25
Electrical planners.....	6	Position feedback.....	8, 27
Engineering.....	7	Position indication	7, 34
Equipment combinations		Positioning signal.....	8, 20, 21, 23, 25, 26
2-port threaded valves.....	9	Positioning time	8, 24
3-port threaded valve.....	9	Power consumption	8, 13
3-port threaded valves.....	9	Power supply.....	25
Fail safe function	8, 23, 25, 28, 32	Power transmission	7
Fitting		Print.....	7
Accessories.....	15	Product description.....	7
Stroke actuators	14	Product replacements	10
Forced control.....	25, 30	Electrical accessories.....	11

Stroke actuators SQX.. zu SAX.....	10
Quality assurance.....	6
Reference documents.....	5
Request to the reader	6
Revision history.....	5
Revision numbers.....	44
Scope of this documentation	6
Signal priorities.....	28
Sizing.....	12
Spare parts.....	11
Status indication.....	7
Stroke model.....	24
Symbols	45
Technical data.....	36
Technical design.....	31

Terms	45
Trademarks.....	5
Transmission of power.....	31
Type summary	
Stroke actuators	8
Use	7
User interface	7
voltage drop.....	12
Volumendurchfluss	26
Warranty	13
Weather shield.....	17, 35
Wire cross-sectional area	12
Wire endings.....	18
Wiring.....	17, 18
Yoke	7

Siemens Switzerland Ltd
Building Technologies Division
International Headquarters
Gubelstrasse 22
6301 Zug
Switzerland
Phone +41 41-724 24 24
www.siemens.com/buildingtechnologies

© Siemens Switzerland Ltd, 2015
Technical specifications and availability subject to change without notice.